



# GOVERNMENT OF THE REPUBLIC OF MAURITIUS

## BIDDING DOCUMENTS

*for*

## CONSTRUCTION OF NEW FISHERIES POST AT CASE NOYALE

**Procurement Reference No: MOF/Q45/2017/ONB3**

Ministry of Ocean Economy, Marine Resources, Fisheries and Shipping  
4<sup>th</sup> Floor, LIC Centre,  
President John Kennedy Street,  
Port Louis

23 November 2017

## Invitation for Bids (IFB)

### MINISTRY OF OCEAN ECONOMY, MARINE RESOURCES, FISHERIES AND SHIPPING

#### Invitation for Bids (IFB)

Authorised under Section (14)2 of the Public Procurement Act

1. The **Ministry of Ocean Economy, Marine Resources, Fisheries and Shipping** invites sealed bids from eligible and qualified bidders of the **Construction of New Fisheries Post at Case Noyale** as more fully described in the bid documents. Bidding shall be conducted through National Advertised Bidding Procedures according to the Public Procurement Act 2006.

The construction period is **210 days** from date of commencement of work.

2. Interested eligible bidders may obtain further information from **The Senior Chief Executive, Ministry of Ocean Economy, Marine Resources, Fisheries and Shipping, 4th Floor, LIC Centre, President John Kennedy Street, Port Louis** and inspect the Bidding Documents at the address given in paragraph 7 from **0900 to 1500 hrs.**
3. Qualifications requirements include:
  - Contractors having the technical capacity, resources and sound financial situations, and
  - As per other qualifying criteria mentioned in the bid documents.
4. A complete set of Bidding Documents in English may be purchased by interested bidders on calling at the address in paragraph 7 and upon payment of a non-refundable fee **Rs. 2,500.00**. The method of payment will be *either by cash or by crossed bank cheque to the order of the Government of Mauritius*.
5. Bids should be deposited in the Quotation/Tender Box located at **Level 4, LIC Centre, John Kennedy St, Port-Louis, not later than Wednesday 20th December 2017 by 13hrs 30.** Bids by post or hand delivered should reach the above address by the same date and time at latest. Late bids will be rejected.

Electronic bidding **shall not** be permitted. Late bids will be rejected. Bids will be opened physically in the presence of the bidders' representatives who choose to attend in person **on same day** at the stated address: **The Conference room, 4th Floor, LIC Centre, President John Kennedy Street, Port Louis at 1400hrs.**

6. All bids shall be accompanied by a duly signed Bid Securing Declaration Form included in the bid document.

7. The address referred to above are:

For consulting and purchasing bid document:

**The Procurement Unit  
Ministry of Ocean Economy, Marine Resources,  
Fisheries and Shipping  
Ground Floor, LIC Centre,  
President John Kennedy Street,  
Port Louis**

For submission of bids and to attend to bid opening:

**Ministry of Ocean Economy, Marine Resources,  
Fisheries and Shipping  
4th Floor, LIC Centre,  
President John Kennedy Street,  
Port Louis**

---

# Summary Description

This Standard Bidding Document for Procurement of Works is to be used when a prequalification process has not taken place before bidding and, therefore, post-qualification applies. A brief description of these documents is given below.

## SBD for Procurement of Works

### PART 1 – BIDDING PROCEDURES

#### Section I. Instructions to Bidders (ITB)

This Section provides relevant information to help Bidders prepare their bids. Information is also provided on the submission, opening, and evaluation of bids and on the award of Contracts. **Section I contains provisions that are to be used without modification.**

#### Section II. Bidding Data Sheet

This Section consists of provisions that are specific to each procurement and that supplement the information or requirements included in Section I, Instructions to Bidders.

#### Section III. Bidding Forms

This Section contains the forms which are to be completed by the Bidder and submitted as part of his Bid.

#### Section IV. Evaluation Criteria

This section contains supplementary evaluation criteria which the Employer may choose to apply to the procurement under consideration.

### PART 2 – EMPLOYER'S REQUIREMENTS

#### Section V. Employer's Requirements

This Section contains the Specification, the Drawings, and supplementary information that describe the Plant and Installation Services to be procured.

### PART 3 – CONDITIONS OF CONTRACT AND CONTRACT FORMS

#### Section VI. General Conditions of Contract

This Section contains the general clauses to be applied in all contracts. **The text of the clauses in this Section shall not be modified.**

## **Section VII. Particular Conditions of Contract**

The contents of this Section supplement the General Conditions of Contract and shall be prepared by the Employer.

## **Section VIII. Contract Forms**

This Section contains forms which, once completed, will form part of the Contract. The forms for **Performance Security** and **Advance Payment Security**, when required, shall only be completed by the successful Bidder after contract award.

---

# Standard Bidding Document

## Table of Contents

<b>PART 1 – Bidding Procedures.....</b>	<b>1</b>
Section 1 - Instructions to Bidders .....	2
Section II- Bidding Data Sheet .....	19
Section III - Bidding Forms .....	24
Section IV - Evaluation Criteria .....	34
<b>PART 2 – Employer’s Requirements.....</b>	<b>36</b>
Section V - Employer’s Requirements .....	37
<b>PART 3 – Conditions of Contract and Contract Forms .....</b>	<b>127</b>
Section VI. General Conditions of Contract .....	128
Section VII. Particular Conditions of Contract.....	129
Section VIII - Contract Forms .....	135
 <b>Annex 1 - Standard Specifications</b>	

# **PART 1 – Bidding Procedures**

# Section 1 - Instructions to Bidders

## Table of Clauses

<b>A.</b>	<b>General.....</b>	<b>4</b>
1.	Scope of Bid .....	4
2.	Source of Fund .....	4
3.	Challenge and Appeal .....	4
4.	Fraud and Corruption .....	4
5.	Eligible Bidders .....	6
6.	Qualifications of Bidders.....	8
<b>B.</b>	<b>Contents of Bidding Document.....</b>	<b>9</b>
7.	Sections of Bidding Document.....	9
8.	Clarification of Bidding Document .....	10
9.	Site visit/Pre-bid meeting .....	10
10.	Amendment of Bidding Document .....	10
<b>C.</b>	<b>Preparation of Bids .....</b>	<b>11</b>
11.	Cost of Bidding .....	11
12.	Language of Bid .....	11
13.	Documents Comprising the Bid .....	11
14.	Bid Submission Form and Schedules .....	11
15.	Alternative Proposal .....	11
16.	Bid Prices and Discounts.....	11
17.	Currencies of Bid and Payment.....	12
18.	Documents Comprising the Technical Proposal .....	12
19.	Period of Validity of Bids .....	12
20.	Bid Security/Bid Securing Declaration .....	12
21.	Format and Signing of Bid .....	13
<b>D.</b>	<b>Submission and Opening of Bids .....</b>	<b>13</b>
22.	Sealing and Marking of Bids.....	13
23.	Deadline for Submission of Bids.....	14
24.	Late Bids.....	14
25.	Withdrawal, Substitution, and Modification of Bids .....	14
26.	Bid Opening .....	14
<b>E.</b>	<b>Evaluation and Comparison of Bids .....</b>	<b>14</b>
27.	Confidentiality.....	14
28.	Clarification of Bids .....	14
29.	Determination of Responsiveness .....	14
30.	Nonconformities, Errors, and Omissions .....	15



---

31.	Correction of Arithmetical Errors .....	15
32.	Margin of Preference .....	16
33.	Evaluation of Bids .....	16
34.	Comparison of Bids .....	16
35.	Qualification of the Bidder .....	16
36.	Employer’s Right to Accept Any Bid, and to Reject Any or All Bids.....	16
<b>F.</b>	<b>Award of Contract .....</b>	<b>17</b>
37.	Award Criteria .....	17
38.	Notification of Award .....	17
39.	Signing of Contract .....	17
40.	Performance Security .....	17
	Preference Security .....	18
41.	Advance Payment and Security.....	18
42.	Plant and Materials on site .....	18
43.	Debriefing.....	18

## Section I - Instructions to Bidders

### A. General

1. **Scope of Bid**
  - 1.1 The Public Body as defined<sup>1</sup> in Section II “Bidding Data Sheet” (**BDS**) also referred to herein as Employer invites bids for the construction of Works, as **described in the BDS** and Section VII, “Particular Conditions of Contract” (**PCC**).

The name and identification number of the Contract are **provided in the BDS and the PCC**.
  - 1.2 The successful Bidder shall be expected to complete the Works by the Intended Completion Period **specified in the BDS**.
  - 1.3 Throughout these bidding documents, the terms:
    - (a) “writing” means any typewritten or printed communication, including e-mail and facsimile transmission,
    - (b) “day” means calendar day, and
    - (c) Singular also means plural.
2. **Source of Fund**
  - 2.1 The Works shall be financed by the Public Body’s own budgetary allocation, **unless otherwise stated in the BDS**.
3. **Challenge and Appeal**
  - 3.1 Unsatisfied bidders shall follow procedures prescribed in Regulations 48, 49 and 50 of the Public Procurement Regulations 2008 to challenge procurement proceedings and award of procurement contracts or to file application for review at the Independent Review Panel.
  - 3.2 Addresses to forward Challenges or Application for Review are **specified in the BDS**.
4. **Fraud and Corruption**
  - 4.1 The Government of the Republic of Mauritius requires that bidders/suppliers/contractors, participating in procurement in Mauritius, observe the highest standard of ethics during the procurement process and execution of contracts.
  - 4.2 Bidders, suppliers and public officials shall be aware of the provisions stated in sections 51 and 52 of the Public Procurement Act which can be consulted on the website of the Procurement Policy Office (PPO): [ppo.govmu.org](http://ppo.govmu.org)

---

<sup>1</sup> See Section IV, “General Conditions of Contract,” Clause 1. Definitions.

- 4.3 The Employer will reject a proposal for award if it determines that the Bidder recommended for award has, directly or through an agent, engaged in corrupt, fraudulent, collusive, coercive or obstructive practices in competing for the contract in question;

For the purposes of this Sub-Clause:

- (i) “corrupt practice” is the offering, giving, receiving or soliciting, directly or indirectly, of anything of value to influence improperly the actions of another party;
  - (ii) “fraudulent practice” is any act or omission, including a misrepresentation, that knowingly or recklessly misleads, or attempts to mislead, a party to obtain a financial or other benefit or to avoid an obligation;
  - (iii) “collusive practice” is an arrangement between two or more parties designed to achieve an improper purpose, including to influence improperly the actions of another party;
  - (iv) “coercive practice” is impairing or harming, or threatening to impair or harm, directly or indirectly, any party or the property of the party to influence improperly the actions of a party;
  - (v) “obstructive practice” is deliberately destroying, falsifying, altering or concealing of evidence material to the investigation or making false statements to investigators in order to materially impede an investigation into allegations of a corrupt, fraudulent, coercive or collusive practice; and/or threatening, harassing or intimidating any party to prevent it from disclosing its knowledge of matters relevant to the investigation or from pursuing the investigation
- 4.4 The Employer commits itself to take all measures necessary to prevent fraud and corruption and ensures that none of its staff, personally or through his/her close relatives or through a third party, will in connection with the bid for, or the execution of a contract, demand, take a promise for or accept, for him/herself or third person, any material or immaterial benefit which he/she is not legally entitled to. If the Employer obtains information on the conduct of any of its employees which is a criminal offence under the relevant Anti-Corruption Laws of Mauritius or if there be a substantive suspicion in this regard, he will inform the relevant authority (ies) and in addition can initiate disciplinary actions. Furthermore, such bid shall be rejected.

- 5. Eligible Bidders**
- 5.1 (a) In accordance with CIDB (Registration of Consultant and Contractors) Regulation 2014, Contractors currently operating in the construction industry have the statutory obligation to be registered with the Construction Industry Development Board (CIDB) accordingly.
- (b) Foreign contractors as defined in the CIDB Act will have to apply for and obtain a Provisional Registration prior to bidding for this project. If the contract is awarded to the foreign contractor the latter shall have to apply for and obtain a Temporary Registration before starting the project.
- (c) Contractors whether local or foreign under an existing or intended joint venture will be eligible as a joint venture if, in addition to their respective individual registration, they obtain a Provisional Registration for the joint venture prior to bidding for this project. If an existing or intended joint venture is awarded the contract it shall have to apply for a Temporary Registration prior to starting the project.
- (d) Sub-contractors undertaking works for value Rs 500 000 or above are subject to registration as applicable to Contractors.
- (e) Bidders are strongly advised to consult the website of the CIDB [cidb.govmu.org](http://cidb.govmu.org) for further details concerning registration of contractors.
- 5.2 (a) Subject to ITB 5.4, a Bidder, and all parties constituting the Bidder, may have the nationality of any country except in the case of open national bidding where the bidding documents may limit participation to citizens of Mauritius or entities incorporated in Mauritius, if so qualified in the BDS.
- (b) Bidder may be natural person, private entity, or government-owned entity or any combination of them in the form of a joint venture.
- (c) Bids submitted by a joint venture of two or more firms as partners shall comply with the following requirements, unless otherwise stated in the **BDS**:
- (i) the Bid shall include all the information listed in ITB Sub-Clause 6.2 below for each joint venture partner;
- (ii) the Bid shall be signed so as to be legally binding on all partners;
- (iii) the Bid shall include a copy of the agreement entered into by the joint venture partners defining the division of assignments to each partner and establishing that all partners shall be jointly and severally liable for the

execution of the Contract in accordance with the Contract terms; alternatively, a Letter of Intent to execute a joint venture agreement in the event of a successful bid shall be signed by all partners and submitted with the bid, together with a copy of the proposed agreement;

(iv) one of the partners shall be nominated as being in charge, authorized to incur liabilities, and receive instructions for and on behalf of any and all partners of the joint venture; and

(v) the execution of the entire Contract, including payment, shall be done exclusively with the partner in charge.

5.3 A Bidder shall not have a conflict of interest. All Bidders found to have a conflict of interest shall be disqualified. A Bidder may be considered to have a conflict of interest with one or more parties in this bidding process, if :

(a) they have a controlling partner in common; or

(b) they receive or have received any direct or indirect subsidy from any of them; or

(c) they have the same legal representative for purposes of this bid; or

(d) they have a relationship with each other, directly or through common third parties, that puts them in a position to have access to information about or influence on the Bid of another Bidder, or influence the decisions of the Employer regarding this bidding process; or

(e) a Bidder participates in more than one bid in this bidding process. Participation by a Bidder in more than one Bid will result in the disqualification of all Bids in which the party is involved. However, this does not limit the inclusion of the same subcontractor in more than one bid; or

(f) a Bidder or any of its affiliates participated as a consultant in the preparation of the design or technical specifications of the contract that is the subject of the Bid; or

(g) a Bidder, or any of its affiliates has been hired (or is proposed to be hired) by the Employer as Engineer for the contract.

5.4 (a) A bidder that is under a declaration of ineligibility by the Government of Mauritius in accordance with applicable

laws at the date of the deadline for bid submission and thereafter shall be disqualified

- (b) Bids from contractors appearing on the ineligibility lists of African Development Bank, Asian Development Bank, European Bank for Reconstruction and Development, Inter-American Development Bank Group and World Bank Group shall be rejected.

Links for checking the ineligibility lists are available on the PPO's website: [ppo.govmu.org](http://ppo.govmu.org)

- 5.5 Government-owned enterprises in the Republic of Mauritius shall be eligible only if they can establish that they are legally and financially autonomous and operate under commercial law, and that they are not a dependent agency of the Government.

## 6. Qualifications of Bidders

- 6.1 All bidders shall provide in Section III, a preliminary description of the proposed work method and schedule, including drawings and charts, as necessary.
- 6.2 Bidders shall include the information and documents listed hereunder with their bids, unless otherwise **stated in the BDS**. If, after opening of bids, it is found that any document is missing, the Employer may request the submission of that document subject to clause 30. The non-submission of the documents by the Bidder within the prescribed period may lead to the rejection of its bid.
- (a) valid registration certificate with the CIDB;
  - (b) copies of original documents defining the constitution or legal status, place of registration, and principal place of business of the Bidder;
  - (c) major items of construction equipment proposed to carry out the Contract;
  - (d) qualifications and experience of key site personnel and technical personnel proposed for the contract;
  - (e) report on the financial standing of the Bidder for the last three years, such as certified copies of Financial Statements/Audited Accounts as filed at the Registrar of Companies before the deadline set for submission of bids. Bidders to provide key financial information extracted from audited accounts/financials statement showing the financial soundness as per PPO Directive No 31;

- (f) Bidders to demonstrate access to, or availability of adequacy of cash-flow or financial resources such as liquid assets, lines of credit, and other financial means, other than any contractual advance payments to meet the overall cash flow requirement for the contract and its current commitments;
  - (g) authority to seek references from the Bidder's bankers;
  - (h) information regarding any litigation, current or during the last five years, in which the Bidder was/is involved, the parties concerned, the issues involved, the disputed amounts, and awards; and
  - (i) proposals for subcontracting components of the Works amounting to more than 10 percent of the Contract Price.
- 6.3 To qualify for award of the Contract, bidders shall meet the following minimum qualifying criteria:
- a) registered with the CIDB under the grade **specified in the BDS**.
  - (b) registered with the CIDB under field of specialisation **specified in the BDS**;
  - (c) proposals for the timely acquisition (own, lease, hire, etc.) of the essential equipment **listed in the BDS**;
  - (d) a Contract Manager/Supervisor with five years' experience in works of an equivalent nature and volume, including no less than three years as Manager or as otherwise **specified in the BDS**; and
  - (e) financially sound in terms of profitability and liquidity as well demonstrating access to or availability of adequacy of cash-flow or financial resources such as liquid assets, lines of credit, and other financial means, other than any contractual advance payments to meet the overall cash flow requirement for the contract and its current commitments in the amount as **specified in the BDS**

Pending litigations against the Applicant or any partner of a Joint Venture may result in Disqualification.

## **B. Contents of Bidding Document**

### **7. Sections of Bidding Document**

- 7.1 The Bidding Document consists of all the Sections indicated below, and should be read in conjunction with any Addenda issued in accordance with ITB 10.

Section I - Instructions to Bidders (ITB)

Section II- Bidding Data Sheet  
Section III - Bidding Forms  
Section IV - Evaluation Criteria  
Section V - Employer's Requirements  
Section VI – General Conditions of Contract  
Section VII- Particular Conditions of Contract  
Section VIII - Contract Forms

7.2 The Invitation for Bids issued by the Employer is not part of the Bidding Document.

**8. Clarification of Bidding Document**

8.1 A prospective Bidder requiring any clarification of the Bidding Document shall contact the Employer in writing at the Employer's address **indicated in the BDS**.

The Employer will respond in writing to any request for clarification, provided that such request is received 15 days prior to the deadline for submission of bids.

Should the Employer deem it necessary to amend the Bidding Document as a result of a request for clarification, it shall do so following the procedure under ITB 10.

**9. Site visit/Pre-bid meeting**

9.1 Bidders, at the Bidders' own responsibility and risk, are encouraged to visit and examine the Site of Works and its surroundings and obtain all information that may be necessary for preparing their Bids and entering into a contract for construction of the Works. The costs of visiting the Site shall be at the Bidders' own expense.

9.2 The Bidder or its designated representative is invited to attend a pre-bid meeting, as **provided for in the BDS**. The purpose of the pre-bid meeting will be to clarify issues and to answer questions on any matter that may be raised at that stage.

Non-attendance at the pre-bid meeting will not be a cause for disqualification of a bidder.

**10. Amendment of Bidding Document**

At any time prior to the deadline for submission of bids, the Employer may amend the Bidding Document by issuing addenda and extend the deadline for submission of bids, if needed.



## C. Preparation of Bids

- 11. Cost of Bidding** 11.1 The Bidder shall bear all costs associated with the preparation and submission of its Bid, and the Employer shall in no case be responsible or liable for those costs irrespective of the outcome of the bidding process.
- 12. Language of Bid** 12.1 The Bid, supporting documents as well as all correspondence relating to the bid exchanged by the Bidder and the Employer shall be in English Language.
- 13. Documents Comprising the Bid** 13.1 The Bid shall comprise the following:
- (a) Bid submission Form (in the format indicated in Section III);
  - (b) Qualification information and documentary evidence establishing the Bidder's qualifications to perform the contract;
  - (c) Technical Proposal as per ITB 18.1;
  - (d) completed Bill of Quantities / Activity Schedule;
  - (e) Bid Security as per the format provided in section III or as a subscription to a Bid Securing Declaration in the Bid Submission Form; and
  - (f) any other material required to be completed and submitted by bidders, as specified in ITB **and the BDS**.
- 14. Bid Submission Form and Schedules** 14.1 The Bid Submission Form, Schedules, and all documents listed under ITB 13.1 shall be prepared using the relevant forms, if so provided.
- 15. Alternative Proposal** 15.1 Alternative Technical Proposals and completion dates if allowed shall be indicated in Section V- Specifications. The evaluation methodologies for their consideration shall be given in Section IV.
- 16. Bid Prices and Discounts** 16.1 The Contract shall be for the whole Works, as described in ITB Sub-Clause 1.1, based on the priced Activity Schedule/Bill of Quantities<sup>2</sup> submitted by the Bidder.
- 16.2 Bidders shall fill in rates and prices for all items of the Works described in the Bill of Quantities.<sup>3</sup> Items for which no rate or price is entered by Bidders, shall not be paid for by the Public Body when executed and shall be deemed covered by the other rates and prices in the Bill of Quantities.

---

<sup>2</sup> In lump sum contracts, delete "priced Bill of Quantities" and replace with "priced Activity Schedule."

<sup>3</sup> In lump sum contracts, delete "described in the Bill of Quantities" and replace with "described in the drawings and specifications and listed in the Activity Schedule."

Corrections, if any, shall be made by crossing out, initialing, dating and rewriting.

16.3 All duties, taxes, and other levies payable by the Contractor under the Contract, or for any other cause, as of the date 14 days prior to the deadline for submission of bids, shall be included in the rates, prices, and total Bid price submitted by Bidders.<sup>4</sup>

16.4 The price to be quoted in the Bid Submission Form shall be the total price of bid after any discount offered.

The discount if any and the conditions of its application shall be indicated separately.

**17. Currencies of Bid and Payment** 17.1 The bid price and rates shall be in Mauritian Rupees and fixed for the duration of the contract unless otherwise **specified in the BDS.**

17.2 Unless otherwise **specified in BDS** interim payment for Plant and Material on site is applicable as per GCC 39.7.

**18. Documents Comprising the Technical Proposal** 18.1 The Bidder shall furnish a Technical Proposal including a statement of work methods, equipment, personnel, schedule and any other information as stipulated in the Bidder Qualification Form (section III), in sufficient details to demonstrate the adequacy of the Bidders' proposal to meet the work requirements and the completion time.

**19. Period of Validity of Bids** 19.1 Bids shall remain valid for a period of 90 days after the bid submission deadline prescribed by the Employer unless otherwise **specified in the BDS.**

19.2 In exceptional circumstances, prior to expiry of the original bid validity period, the Employer may request that the bidders extend the period of validity for a specified additional period. The request and the responses thereto shall be made in writing.

**20. Bid Security/Bid Securing Declaration** 20.1 The Bidder shall furnish either a subscription to a Bid Securing Declaration or a Bid Security in its original form with its bid as part of its bid, if so **required in the BDS.**

20.2 Bid Security shall be in the form of a Bank Guarantee from a local commercial bank as per the format contained in section III and shall be valid for a period of 30 days beyond the validity period of the bid or beyond any period of extension.

---

<sup>4</sup> *In lump sum contracts, delete "rates, prices, and."*

20.3 Any bid not accompanied by an enforceable and substantially compliant Bid Security or a subscription to a Bid Securing Declaration in the Bid Submission Form, if required in accordance with ITB 20.1, shall be rejected by the Employer as non-responsive.

20.4 Bid Security shall be forfeited or the Bid Securing declaration exercised for non-compliance on the part of the Bidder for reasons mentioned in the Bid Security format contained in Section III or the Bid Suring Declaration contained as Appendix to the Bid Submission Form.

## **21. Format and Signing of Bid**

21.1 The Bidder shall prepare one original of the documents comprising the bid as described in ITB 13.1 and clearly mark it "ORIGINAL". In addition, the Bidder shall submit **two copies** of the bid and clearly mark each of them "COPY." In the event of any discrepancy between the original and the copies, the original shall prevail.

21.2 The original and all copies of the bid shall be typed or written in indelible ink and shall be signed by a person duly authorized to sign on behalf of the Bidder.

## **D. Submission and Opening of Bids**

### **22. Sealing and Marking of Bids**

22.1 Bidders may always submit their bids by mail or by hand. Procedures for submission, sealing and marking are as follows:

(a) Bidders submitting bids by mail or by hand shall enclose the original and each copy of the Bid, including alternative bids, if permitted in accordance with ITB 15, in separate sealed envelopes, duly marking the envelopes as "ORIGINAL", "ALTERNATIVE" and "COPY." These envelopes containing the original and the copies shall then be enclosed in one single envelope. The rest of the procedure shall be in accordance with ITB sub-Clauses 22.2.

22.2 The inner and outer envelopes shall:

(a) bear the name and address of the Bidder;

(b) be addressed to the Employer as indicated in ITB 22.1;

(c) bear the specific identification of this bidding process indicated in accordance with ITB 1.1; and

(d) bear a warning not to open before the time and date for bid opening.

- 23. Deadline for Submission of Bids** 23.1 Bids shall be delivered to the Employer at the address and no later than the time and date **specified in the BDS**.
- The Employer may, at its discretion, extend the deadline for the submission of bids by amending the Bidding Document in accordance with ITB 10.
- 24. Late Bids** 24.1 Late bids shall not be considered. They will be returned unopened
- 25. Withdrawal, Substitution, and Modification of Bids** 25.1 No bid may be withdrawn, substituted, or modified in the interval between the deadline for submission of bids and the expiration of the period of bid validity specified by the Bidder on the Bid submission Form or any extension thereof.
- 26. Bid Opening** 26.1 The Employer shall open the bids at the time place and address **specified in the BDS** in the presence of Bidders` designated representatives who choose to attend.
- 26.2 The bidders' names, the Bid Prices, the total amount of each bid, any discounts, any alternative bid, bid modifications and withdrawals, the presence or absence of bid security, and such other details as the Employer may consider appropriate, will be announced and recorded by the Employer at the opening.
- E. Evaluation and Comparison of Bids**
- 27. Confidentiality** 27.1 Information relating to the examination, evaluation, comparison, and post-qualification of bids and recommendation of contract award, shall not be disclosed to Bidders or any other person not officially concerned with such process.
- 27.2 Any attempt by a Bidder to influence the Employer in the evaluation of the bids or Contract award decisions may result in the rejection of its bid.
- 28. Clarification of Bids** 28.1 To assist in the examination, evaluation, and comparison of the bids, and qualification of the Bidders, the Employer may, at its discretion, ask any Bidder for a clarification of its bid. No change in the prices or substance of the bid shall be sought, offered, or permitted, except to confirm the correction of arithmetical errors discovered by the Employer in the evaluation of the bids, in accordance with ITB 31.
- 29. Determination of Responsiveness** 29.1 The Employer`s determination of a bid`s responsiveness is to be based on the contents of the bid itself, as defined in ITB13.

29.2 A substantially responsive bid is one that meets the requirements of the Bidding Document without material deviation, reservation, or omission.

29.3 The Employer shall examine the technical aspects of the bid submitted in accordance with ITB 18, Technical Proposal, in particular, to confirm that all requirements of Section IV (Employer's Requirements) have been met without any material deviation, reservation or omission.

29.4 If a bid is not substantially responsive to the requirements of the Bidding Document, it shall be rejected by the Employer and may not subsequently be made responsive by correction of the material deviation, reservation, or omission.

**30. Nonconformities, Errors, and Omissions**

30.1 Provided that a bid is substantially responsive, the Employer may waive any non-material non-conformity in the bid, request that the Bidder submit the necessary information or documentation, to rectify nonmaterial nonconformities in the bid related to documentation requirements but not related to any aspect of the price of the bid; and shall rectify quantifiable nonmaterial nonconformities related to the Bid Price.

**31. Correction of Arithmetical Errors**

31.1 Provided that the bid is substantially responsive, the Employer shall correct arithmetical errors on the following basis:

- (a) only for unit price contracts, if there is a discrepancy between the unit price and the total price that is obtained by multiplying the unit price and quantity, the unit price shall prevail and the total price shall be corrected, unless in the opinion of the Employer there is an obvious misplacement of the decimal point in the unit price, in which case the total price as quoted shall govern and the unit price shall be corrected;
- (b) if there is an error in a total corresponding to the addition or subtraction of subtotals, the subtotals shall prevail and the total shall be corrected; and
- (c) if there is a discrepancy between words and figures, the amount in words shall prevail, unless the amount expressed in words is related to an arithmetic error, in which case the amount in figures shall prevail subject to (a) and (b) above.

- 32. Margin of Preference** 32.1 **Unless otherwise specified in the BDS**, Margin of preference shall not apply.
- 33. Evaluation of Bids** 33.1 The Employer shall use the criteria and methodology defined in this clause and no other evaluation criteria or methodologies shall be permitted.
- 33.2 To evaluate a bid, the Employer shall consider the following:
- (a) the bid price, excluding Provisional Sums and the provision, if any, for contingencies in the Summary Bill of Quantities for admeasurement contracts or Schedule of Prices for lump sum contracts, but including Daywork items, where priced competitively; and
  - (b) price adjustment for correction of arithmetic errors, discounts, non-conformities, due to the supplementary criteria as defined in Section IV, and Margin of Preference, if applicable.
- 33.3 If this Bidding Document allows Bidders to quote separate prices for different contracts, and to award multiple contracts to a single Bidder, the methodology to determine the lowest evaluated price of the contract combinations, including any discount offered in the Bid Submission Form, is specified in Section IV (Evaluation and Qualification Criteria).
- 33.4 If the bid for an admeasurement contract, which results in the lowest Evaluated Bid Price, is seriously unbalanced, front loaded or substantially below updated estimates or if any item in the Priced Activity Schedule is front loaded or contains an erroneous amount in the opinion of the Employer, the Employer may after clarification require the Bidder to produce detailed price analysis for any or all items that the amount of the performance security be increased at the expense of the Bidder.
- 34. Comparison of Bids** 34.1 The Employer shall compare all substantially responsive bids in accordance with ITB 33 to determine the lowest evaluated bid.
- 35. Qualification of the Bidder** 35.1 The Employer shall determine to its satisfaction whether the Bidder that is selected as having submitted the lowest evaluated substantially responsive bid meets the qualifying criteria.
- 36. Employer's Right to Accept Any Bid, and to Reject Any or All Bids** 36.1 The Employer reserves the right to accept or reject any bid, and to annul the bidding process and reject all bids at any time prior to contract award, without thereby incurring any liability to Bidders.

## F. Award of Contract

- 37. Award Criteria** 37.1 Subject to ITB 36.1, the Employer shall award the Contract to the Bidder whose offer has been determined to be the lowest evaluated bid and is substantially responsive to the Bidding Document, provided further that the Bidder is determined to be qualified to perform the Contract satisfactorily.
- 38. Notification of Award** 38.1 Prior to the expiration of the period of bid validity, the Employer shall, for contract amount above the prescribed threshold, notify the selected bidder of the proposed award and accordingly notify unsuccessful bidders. Subject to Challenge and Appeal the Employer shall notify the selected Bidder, in writing, by a Letter of Acceptance for award of contract. The Letter of Acceptance shall specify the sum that the Employer will pay the Contractor in consideration of the execution and completion of the Works (hereinafter and in the Conditions of Contract and Contract Forms called “the Contract Price”) and the requirement for the Contractor to remedy any defects therein as prescribed by the Contract. Within seven days from the issue of Letter of Acceptance, the Employer shall publish on the Public Procurement Portal ([publicprocurement.govmu.org](http://publicprocurement.govmu.org)) and the Employer’s website, the results of the Bidding Process identifying the bid and lot numbers and the following information:
- (i) name of the successful Bidder, and the Price it offered, as well as the duration and summary scope of the contract awarded; and
  - (ii) an executive summary of the Bid Evaluation Report.
- 38.2 Until a formal contract is prepared and executed, the notification of award shall constitute a binding Contract.
- 39. Signing of Contract** 39.1 Promptly upon issue of Letter of Acceptance, the Employer shall send to the successful Bidder the Contract Agreement.
- 39.2 Within twenty-one (21) days of receipt of the Contract Agreement, the successful Bidder shall sign, date, and return it to the Employer.
- 40. Performance Security** 40.1 Within twenty-one (21) days of the receipt of the Letter of Acceptance from the Employer, the successful Bidder shall furnish the Performance Security in accordance with the conditions of contract, using for that purpose the Performance Security Form included in Section VIII (Contract Forms).
- 40.2 Failure of the successful Bidder to submit the above-

mentioned Performance Security or to sign the Contract Agreement within the prescribed delay shall constitute sufficient grounds for the annulment of the award and forfeiture of the bid security.

- Preference Security** 40.3 The successful bidder having benefitted from a Margin of Preference shall provide a Preference Security, **as specified in the BDS**. The amount for the Preference Security shall be the difference between the price quoted by the selected bidder and that of the lowest evaluated bid which would have been selected for award of contract, if the said Margin of Preference was not applicable
- 41. Advance Payment and Security** 41.1 The Public Body shall provide an Advance Payment on the Contract Price as stipulated in the GCC, subject to a maximum amount, as stated in the BDS. The Advance Payment shall be guaranteed by a security as per the format contained in Section VIII.
- 42. Plant and Materials on site** 42.1 Unless otherwise **specified in BDS** interim payment for Plant and Material on site is applicable as per GCC 39.7.
- 43. Debriefing** 43.1 The Employer shall promptly attend to all requests for debriefing for the contract, made in writing, and within 30 days from the date of the publication of the award or date the unsuccessful bidders are informed about the award, whichever is the case, by following regulation 9 of the Public Procurement Regulations 2008 as amended.



## Section II- Bidding Data Sheet

<b>A. General</b>	
<b>ITB 1.1</b>	<p>The Public Body is:</p> <p><b>Ministry of Ocean Economy, Marine Resources, Fisheries and Shipping 4<sup>th</sup> Floor, LIC Centre, President John Kennedy Street, Port Louis</b></p> <p>The name and identification of the Contract are <b>Construction of New Fisheries Post at Case Noyale</b> and identification number <b>MOF/Q45/2017/ONB3</b></p> <p><b>The project consist of the construction of the main building, an inflammable store, generator room and site works consisting of parking spaces and wastewater disposal system and other ancillary works as more fully described on drawings and specifications..</b></p> <p><b>The main building is a ground and first floor structure in RC concrete and blockwall structure, RC roof slab, render and paint finish to wall and ceiling generally, wall tiles finishes internally, floor tiles, openings, electrical works and other ancillary works as morefully described in drawings.</b></p> <p><b><u>Site Works</u></b> <b>The Site Works includes Parking Facilities, Drive Way , Inflammable Store, Generator room, Flag poles, Water Tank, Boundary Wall, Manholes, Septic Tank, Soakaways, Effluent Filter Tank and Leaching Field, and other works as shown on drawings.</b></p>
<b>ITB 1.2</b>	The Intended Completion period is <b>210 days</b> from start date.
<b>ITB 2.1</b>	The Funding Agency is: <b>Republic of Mauritius</b>
<b>ITB 3.2</b>	<p>The address to file Challenges in respect of this procurement is:</p> <p><b>The Senior Chief Executive Ministry of Ocean Economy, Marine Resources, Fisheries and Shipping 4<sup>th</sup> Floor, LIC Centre, President John Kennedy Street, Port Louis</b></p>

	<p>The address to file Application for Review is:</p> <p style="text-align: center;"><b>The Chairman Independent Review Panel, 9<sup>th</sup> Floor, Wing B Emmanuel Anquetil Building Pope Hennessy Street Port Louis Tel : 2013921</b></p>
<b>ITB 5.4</b>	<p>The list of debarred firms according to the Debarment process may be obtained from the web site of the Procurement Policy Office: <a href="http://ppo.govmu.org">ppo.govmu.org</a></p>
<b>ITB 6.2</b>	<b>Bidders shall include all information and documents required in ITB Sub-Clause 6.2 (a) to (i) with their bids.</b>
<b>ITB 6.2 (e)</b>	<p><b>Bidders shall also submit duly filled Form: Key Financial Information extracted from Audited Accounts/Financial Statements as per format provided in Section III Bidding forms.</b></p> <p>The assessment of the financial soundness of the company shall be on a pass/fail basis on its overall performance including its profitability.</p> <p>Bidders must have earned profit in at least <b>one</b> year over <b>the last (three) 3 years</b>.</p> <p>Financial statements should be for the last <b>three (3) years</b>.</p>
<b>ITB 6.3 (a)</b>	<p>The Contractor must have a valid registration grade of a <b>minimum of Grade F</b> with the CIDB under <b>Building Construction Works</b>.</p> <p>The Contractor must select an Electrical and Mechanical sub-contractor having a valid registration with the CIDB.</p>
<b>ITB 6.3 (b)</b>	Not Applicable
<b>ITB 6.3 (c)</b>	<p>The essential equipment to be made available for the Contract by the successful Bidder shall be: excavator, bobcat, concrete mixer, Excavator, Bobcat, Compressor, Concrete mixer, Elevator, vibrator and other equipment necessary for the works.</p>
<b>ITB 6.3 (d)</b>	<p><b>Key Personnel:</b></p> <p>One Contract Manager with a minimum of 5 years' experience in Contract Management holding at least a degree in Building and Civil Engineering from the University of Mauritius or any similar qualifications and registered with his/her respective council.</p> <p>One Site Agent with a minimum of <b>10</b> years relevant experience and</p>

	<p>holding at least a diploma in Building and Civil Engineering from the University of Mauritius or any similar qualifications.</p> <p>One General Foreman with minimum 10 years relevant experience.</p> <p>One registered Electrical Engineer with a minimum of 5 years' experience.</p> <p>One Electrical Technician with minimum 5 years' experience holding the part II Electrical Engineering Technician's certificate 280 or 803 of the City of Guilds of London or any similar qualifications.</p> <p>One Plumbing Technician with minimum 5 years' experience holding the National Trade Certificate (NTC) in plumbing installation works (Module 1,2,3) issued by the Mauritius Examinations Syndicate and the IVTB or equivalent qualification.</p> <p><b><i>The bidder to submit recent signed C.Vs of the proposed personnel.</i></b></p>
<b>ITB 6.3 (e)</b>	<p>The minimum amount of liquid assets and/or credit facilities net of other contractual commitments of the Bidder shall be <b>Rs 2,500,000</b>.</p> <p>Bidders are required to demonstrate access to, or availability of the above amount of financial resources such as liquid assets, lines of credit, and other financial means, other than any contractual advance payments to meet the overall cash flow requirements for the contract and its current commitments at the time of submission.</p> <p>If Bidders are demonstrating availability of financial resources from financial institutions, the Bidders shall produce original documentary evidence from recognized financial institutions regarding their liquid asset and/or availability of credit facilities, as per given format.</p>
<b>B. Bidding Documents</b>	
<b>ITB 8.1</b>	<p>The Public Body's address for clarification is:</p> <p><b>The Senior Chief Executive Ministry of Ocean Economy, Marine Resources, Fisheries and Shipping 4<sup>th</sup> Floor, LIC Centre, President John Kennedy Street, Port Louis</b></p>
<b>ITB 9.2</b>	<p>A pre-bid meeting has been scheduled for</p> <p><b>Date: Wednesday 6th December 2017</b></p> <p><b>Time: 10.00 hrs at Case Noyale Fisheries Post.</b></p>
<b>C. Preparation of Bids</b>	
<b>ITB 13.1 (f)</b>	Any additional materials required to be completed and submitted by the

	Bidders are <i>None</i> .
<b>ITB 17.1</b>	The Contract is <b>not</b> subject to price adjustment in accordance with GCC Clause 44.
<b>ITB 17.2</b>	Interim Payment for Plant and Material on site is applicable.
<b>ITB 19.1</b>	The Bid shall be valid for <b>90 days</b> after the deadline set for the submission of bid, the deadline being counted as day one of the validity period.
<b>ITB 20.1</b>	Bid shall include a subscription to a <b>Bid Securing Declaration</b>
<b>D. Submission of Bids</b>	
<b>ITB 23.1</b>	The deadline for submission of bids shall be <b>Wednesday 20 December 2017 up to 13.30 hrs at latest.</b>
	The Employer's address for the purpose of Bid submission is <b>The Senior Chief Executive Ministry of Ocean Economy, Marine Resources, Fisheries and Shipping 4<sup>th</sup> Floor, LIC Centre, President John Kennedy Street, Port Louis</b>
<b>E. Evaluation and Comparison of Bids</b>	
<b>ITB 26.1</b>	The bid opening shall take place at:  <b>Conference Room, Ministry of Ocean Economy, Marine Resources, Fisheries and Shipping 4<sup>th</sup> Floor, LIC Centre, President John Kennedy Street, Port Louis</b>  <b>Date: Wednesday 20 December 2017</b> <b>Time: 1400hrs</b>
<b>ITB 32</b>	32.1 A Margin of Preference shall apply as defined hereunder and in Section IV-Evaluation Criteria.  The following procedure shall be used to apply the Margin of Preference:  (a) responsive bids shall be classified into the following groups:  • Group A: bids offered by bidders meeting the conditions

	<p>satisfying eligibility for a Margin of Preference , and</p> <ul style="list-style-type: none"> <li>• Group B: all other bids;</li> </ul> <p>(b) for the purpose of further evaluation and comparison of bids only, all bids classified in Group B shall be increased by the percentage(s) of preference allocated to those in group A.</p> <p>32.2 Bidders applying for the Margin of Preference shall submit, as part of their bidding documents evidence of:</p> <ul style="list-style-type: none"> <li>(a) their incorporation in the Republic of Mauritius;</li> <li>(b) their Joint Venture Agreement or intention to legally enter into a Joint Venture Agreement to be incorporated in the Republic of Mauritius, where applicable;</li> <li>(c) the percentage of the total man-days to be deployed by local manpower with break-down indicating type of works to be entrusted to the local manpower.</li> <li>(d) A financial statement signed by a certified Accountant vouching that the annual turn-over of the local Small and Medium enterprise (where applicable) does not exceed Rs 50M.</li> </ul>
<b>F. Award of Contract</b>	
<b>ITB 40.1</b>	The Standard Form of Performance Security acceptable to the Public Body shall be “a Bank Guarantee”. The Bank guarantee shall be <b>10%</b> of the contract price inclusive of provisional and contingencies sum and VAT.
<b>ITB 40.3</b>	For contracts up to 100M, the public body shall either retain money from progressive payments to constitute the preference security or request a security in the form of a bank guarantee at the selected bidder’s option.
<b>ITB 41</b>	The Advance Payment shall be limited to <b>10%</b> percent of the Contract Price less the provisional and contingencies sums
<b>ITB 42.1</b>	Interim Payment for Plant and Material on site <b>is</b> applicable.

## **Section III - Bidding Forms**

### **Table of Forms**

<b>Bid Submission Form .....</b>	<b>25</b>
<b>Qualification Information .....</b>	<b>29</b>
<b>Key Financial Information extracted from Audited Accounts/Financial Statements.....</b>	<b>32</b>
<b>Form of Bank Certificate .....</b>	<b>33</b>

## Bid Submission Form

*The Bidder must prepare the Bid Submission Form on stationery with its letterhead clearly showing the Bidder's complete name and address.*

*Note: All italicized text is for use in preparing these form and shall be deleted from the final document.*

Date: \_\_\_\_\_  
 Bidder's Reference No.: \_\_\_\_\_  
 Procurement Reference No.: .....

To:

We, the undersigned, declare that:

- (a) We have examined and have no reservations to the Bidding Documents, including Addenda issued in accordance with Instructions to Bidders (ITB) Clause 10;
- (b) We offer to execute in conformity with the Bidding Documents the following Works:

**Construction of New Fisheries Post at Case Noyale;**

- (c) The total price of our Bid after discounts, if any, offered in item (d) below is:  
 \_\_\_\_\_  
 \_\_\_\_\_;
- (d) The discounts offered and the methodology for their application are:  
 \_\_\_\_\_  
 \_\_\_\_\_;
- (e) Our bid shall be valid for a period of **90 days** from the date fixed for the bid submission deadline in accordance with the Bidding Documents, and it shall remain binding upon us and may be accepted at any time before the expiration of that period;
- (f) We hereby confirm that we have read and understood the content of the Bid Securing Declaration attached hereto and subscribe fully to the terms and conditions contained therein, if required. We understand that non-compliance to the conditions mentioned may lead to disqualification.
- (g) If our bid is accepted, we commit to obtain a Performance Security and a Preference Security (if applicable) in accordance with the Bidding Document;
- (h) We, including any subcontractors or suppliers for any part of the contract, do not have any conflict of interest in accordance with ITB 5.4;
- (i) We are not participating, as a Bidder in more than one bid in this bidding process other than alternative offers submitted in accordance with ITB 15;

- (j) Our firm, its affiliates or subsidiaries, including any Subcontractors or Suppliers for any part of the contract, has not been declared ineligible under the laws of Mauritius;
- (k) We are not a government owned entity / We are a government owned entity but meet the requirements of ITB 5.4;<sup>5</sup>
- (l) We hereby “*apply/do not apply*” for Margin of Preference as provided in the bidding document;<sup>6</sup>
- (m) We have taken steps to ensure that no person acting for us or on our behalf will engage in any type of fraud and corruption as per the principles described hereunder, during the bidding process and contract execution:
- i. We shall not, directly or through any other person or firm, offer, promise or give to any of the Public Body’s employees involved in the bidding process or the execution of the contract or to any third person any material or immaterial benefit which he/she is not legally entitled to, in order to obtain in exchange any advantage of any kind whatsoever during the tender process or during the execution of the contract.
  - ii. We shall not enter with other Bidders into any undisclosed agreement or understanding, whether formal or informal. This applies in particular to prices, specifications, certifications, subsidiary contracts, submission or non-submission of bids or any other actions to restrict competitiveness or to introduce cartelisation in the bidding process.
  - iii. We shall not use falsified documents, erroneous data or deliberately not disclose requested facts to obtain a benefit in a procurement proceeding.

We understand that transgression of the above is a serious offence and appropriate actions will be taken against such bidders.

- (n) We understand that this bid, together with your written acceptance, shall constitute a binding contract between us, until a formal contract is prepared and executed;
- (o) We understand that you are not bound to accept the lowest evaluated bid or any other bid that you may receive; and
- (p) If awarded the contract, the person named below shall act as Contractor’s Representative:
- 

---

<sup>5</sup> Use one of the two options as appropriate.

<sup>6</sup> Strike out as appropriate



Name: \_\_\_\_\_

In the capacity of: \_\_\_\_\_

Signed: \_\_\_\_\_

Duly authorized to  
sign the Bid for and  
on behalf of: \_\_\_\_\_

Date: \_\_\_\_\_

Seal of Company \_\_\_\_\_

**MOF/Q45/2017/ONB3**

Appendix to Bid Submission Form

## **Bid Securing Declaration**

By subscribing to the undertaking in respect of paragraph (f) of the Bid Submission form:

I/We\* accept that I/we\* may be disqualified from bidding for any contract with any Public Body for the period of time that may be determined by the Procurement Policy Office under section 35 of the Public Procurement Act, if I am/we are\* in breach of any obligation under the bid conditions, because I/we\*:

- (a) have modified or withdrawn my/our\* Bid after the deadline for submission of bids during the period of bid validity specified by the Bidder in the Letter of Bid; or
- (b) have refused to accept a correction of an error appearing on the face of the Bid; or
- (c) having been notified of the acceptance of our Bid by the **Ministry of Ocean Economy, Marine Resources, Fisheries and Shipping** during the period of bid validity, (i) have failed or refused to execute the Contract, if required, or (ii) have failed or refused to furnish the Performance Security, in accordance with the Instructions to Bidders.

I/We\* understand this Bid Securing Declaration shall cease to be valid (a) in case I/we am/are the successful bidder, upon our receipt of copies of the contract signed by you and the Performance Security issued to you by me/us ; or (b) if I am/we are\* not the successful Bidder, upon the earlier of (i) the receipt of your notification of the name of the successful Bidder; or (ii) thirty days after the expiration of the validity of my/our\* Bid.

In case of a Joint Venture, all the partners of the Joint Venture shall be jointly and severally liable.

## Qualification Information

*[The information to be filled in by **bidders** in the following pages shall be used for purposes of post-qualification or for verification of prequalification as provided for in ITB Clause 6. This information shall not be incorporated in the Contract. Attach additional pages as necessary. Pertinent sections of attached documents should be translated into English. If used for prequalification verification, the Bidder should fill in updated information only.]*

### 1. Individual Bidders or Individual Members of Joint Ventures

- 1.1 Constitution or legal status of Bidder: *[attach copy]*
- Place of registration: *[insert]*
- Principal place of business: *[insert]*
- Registration certificate from the CIDB: *[attach copy]*
- Evidence of signatory authorized to sign the bid ( if applicable): *[attach]*

1.2 Where the specialization category for which the Bidder is required to be registered does not cover adequately the specialization required for the works Bidder shall provide *[insert number]* of works of a nature and amount similar to the Works performed as prime Contractor over the last *[insert number]* years. *[Also list details of work under way or committed, including expected completion date(s).]*

Project/Contract name and country	Name of client and contact person	Type of work performed and year of completion	Value of contract (national currency )
(a)			
(b)			

- 1.3 Major items of Contractor's Equipment proposed for carrying out the Works. *[List all information requested below. Refer also to ITB Sub-Clause 6.3 (c).]*

Item of equipment	Description, make, and age (years)	Condition (new, good, poor) and number available	Owned, leased (from whom?), or to be purchased (from whom?)
(a)			
(b)			

- 1.4 Qualifications and experience of key personnel proposed for administration and execution of the Contract. *[Attach biographical data. Refer also to ITB Sub-Clause 6.3 (d).]*

Position	Name	Years of experience (general)	Years of experience in proposed position
(a)			
(b)			

1.5 Proposed subcontracts and firms involved. Refer to General Conditions of Contract Clause 7.

Sections of the Works	Value of subcontract	Subcontractor (name and address)	Experience in similar work
(a)			
(b)			

*[Bidders have to ascertain that sub-contractors executing works of amount Rs 500 000 are duly registered with the CIDB in accordance with CIDB (Registration of Consultant) Regulation 2014.]*

1.6 Financial reports for the last **three years**: Financial Statements, Audited Accounts, etc. *[List below and attach copies.]*<sup>7</sup>

1.7 Evidence of access to financial resources to meet the qualification requirements: cash in hand, lines of credit, etc. List below and attach copies of support documents.

1.8 Name, address, and telephone, telex, and facsimile numbers of banks that may provide references if contacted by the Public Body.

1.9 Information on current litigation(s) in which the Bidder is involved.

Other party(ies)	Cause of dispute	Amount involved
(a)		
(b)		

1.10 Statement of compliance with the requirements of ITB Sub-Clause 5.4 (e).

1.11 Proposed program (service work and schedule). Description, drawings and charts, as necessary, to comply with the requirement of the bidding documents.

<sup>8</sup> Amount to be inserted by the Guarantor in accordance with Sub-Clause 49.2 of the General Conditions of Contract

- 2. Joint Ventures**
- 2.1 The information listed in 1.1 - 1.9 above shall be provided for each partner of the joint venture.
  - 2.2 The information in 1.11 above shall be provided for the joint venture.
  - 2.3 Attach the power of attorney or other acceptable document of the signatory (ies) of the Bid authorizing signature of the Bid on behalf of the joint venture.
  - 2.4 Attach the Agreement among all partners of the joint venture (and which is legally binding on all partners), which shows that
    - (a) all partners shall be jointly and severally liable for the execution of the Contract in accordance with the Contract terms;
    - (b) one of the partners will be nominated as being in charge, authorized to incur liabilities, and receive instructions for and on behalf of any and all partners of the joint venture; and
    - (c) the execution of the entire Contract, including payment, shall be done exclusively with the partner in charge.
- 3. Additional Requirements**
- 3.1 Bidders should provide any additional information requested in the Bidding Document.

**Form: Key Financial Information extracted from  
Audited Accounts/Financial Statements**

Financial data in the currency reported in the Audited Accounts/Financial Statements	Historical Information			Remarks By BEC
	Previous Years	Last year	Current year	
Statement of Financial Position (Information from Balance Sheet)				
A. Current Assets				
B. Current Liabilities				
Working capital ratio or current ratio( A/B)				
Quick ratio or Acid Test ratio (Current Asset net of stock / B)				
C. Total Assets				
D. Total Liabilities				
Net Worth( C-D)				
Cash in hand and at Bank				
Bank Overdrafts				
Other Liquid Assets				
<b>Information from Income statement</b>				
Key Profitability Indicators in the currency reported in the Audited Accounts/Financial Statements	Previous Years	Last year	Current year	
Turnover				
Profit /(Loss )Before Tax				
Taxation				
Net Profit /(Loss) After Tax				
$\frac{\text{Net profit After tax}}{\text{Turnover}} \times 100$				
<p>Certified by Bidder that information are true extract from Audited Accounts/Financial Statements</p> <p>Name:</p> <p>Signature:</p> <p>Capacity:</p> <p>Date:</p>				

[Bank official Letterhead]

## Form of Bank Certificate

Procurement Ref No: \_\_\_\_\_

Name of project: \_\_\_\_\_

For: \_\_\_\_\_ [name of Public Body]

### THE UNDERSIGNED

[Bank Name]: \_\_\_\_\_

[Address]: \_\_\_\_\_

Certifies that the firm:

\_\_\_\_\_  
[Name of firm and address]

for the purposes of submitting a bid for the above-mentioned project has, at the present time, the financial means and resources for the proper execution of the contract (if awarded) with a minimum of liquid assets and/or credit facilities of (MUR \_\_\_\_\_) net of other contractual commitments.

(In words and figures).

Drawn at \_\_\_\_\_

Date: \_\_\_\_\_

For : \_\_\_\_\_ [Bank Name]

Represented by : \_\_\_\_\_ [Name of officer]

Status: \_\_\_\_\_

Signature: \_\_\_\_\_

[ Bank Seal ]

[Note that the Bidder should ensure that the Bank Certificate submitted by a bank shall be substantially similar to the above format]

## Section IV - Evaluation Criteria

This section contains supplementary criteria that the Employer shall use to evaluate bids.

### 1. Evaluation

In addition to the criteria listed in ITB 33 the following criteria shall apply:

#### (a) Adequacy of Technical Proposal

Evaluation of the Bidder's Technical Proposal will include an assessment of the Bidder's technical capacity to mobilize key equipment and personnel for the contract consistent with its proposal regarding work methods, scheduling, and material sourcing in sufficient detail and fully in accordance with the requirements stipulated in Section V (Employer's Requirements).

#### (b) Multiple Contracts

Pursuant sub-clause 1.1 of the Instructions to Bidders, if Works are grouped in multiple contracts, evaluation will be as follows: **Not applicable**

#### (c) Completion Time

An alternative Completion Time, if permitted under ITB 15.1, will be evaluated as follows: **Not applicable**

#### (d) Technical Alternatives

Technical alternatives, if permitted under ITB 15.1, will be evaluated as follows: **Not applicable**

#### (e) Margin of Preference

A Margin of Preference for employment of local manpower shall be applicable as follows:

##### 1.1 For International Bidding

A bidder, incorporated in the Republic of Mauritius and employing local manpower for 80 % or more of the total man-days deployed for the execution of a Works contract, shall be eligible for a preference of 15 %.

##### 1.2 For National Bidding

- (i) A local Small and Medium Enterprise, having an annual turnover not exceeding Rs 50 million or a joint venture consisting of local Small and Medium Enterprises having an aggregate annual turnover not exceeding Rs 50 million and employing local manpower for 80 % or more of the total man-days deployed for the execution of a Works contract, shall be eligible for a Margin of Preference of 20 %.



- (ii) Any bidder incorporated in the Republic of Mauritius not satisfying all the conditions mentioned in (a) above but employing local manpower for 80 % or more of the total man-days deployed for the execution of a Works contract, shall be eligible for a Margin of Preference of 10 %.

Note: Local manpower shall mean employees on the payroll of the Contractor as well as those for subcontractors executing works on the site.

## **PART 2 – Employer’s Requirements**

## **Section V - Employer's Requirements**

### **Table of Contents**

<b>SCOPE OF WORKS .....</b>	<b>38</b>
<b>SPECIFICATIONS.....</b>	<b>39</b>
<b>LIST OF DRAWINGS .....</b>	<b>97</b>
<b>ACTIVITY SCHEDULE .....</b>	<b>98</b>
<b>MAIN SUMMARY .....</b>	<b>121</b>
<b>PRELIMINARIES AND GENERAL COSTS .....</b>	<b>122</b>

## **Scope of Works**

**The project consist of the construction of the main building, an inflammable store, generator room and site works consisting of parking spaces and wastewater disposal system and other ancillary works as more fully described on drawings and specifications..**

**The main building is a ground and first floor structure in RC concrete and block wall structure, RC roof slab, render and paint finish to wall and ceiling generally, wall tiles finishes internally, floor tiles, openings, electrical works and other ancillary works as more fully described in drawings.**

### **Site Works**

**The Site Works includes Parking Facilities, Drive Way, Inflammable Store, Generator room, Flag poles, Water Tank, Boundary Wall, Manholes, Septic Tank, Soak ways, Effluent Filter Tank and Leaching Field, and other works as shown on drawings.**

## **Specifications and Performance Requirements**

The Government of Mauritius Standard Specifications issued by the Ministry of Public Infrastructure, Land Transport & Shipping shall be deemed to form part of these bidding documents, as every contractor registered with the Ministry Public Infrastructure, Land Transport & Shipping has, de facto, a copy of the said Specifications.

However, should the Bidder require a fresh copy of the Specifications in connection with this Bidding Documents, he/they should make an application in writing to the Senior Chief Executive, Ministry Public Infrastructure, Land Transport & Shipping, Quantity Surveying Section, Phoenix.

All materials used in this project should be to the approval of the Architect and Engineer

With reference to the "Standard Specifications", kindly note that:-

Page 35 of the "Standard Specifications" – Paragraph (c)

An Approved Testing Authority is further defined as:-

- (i) Materials Testing Laboratory
- (ii) Mauritius Standard Bureau
- (iii) The Laboratory of the University of Mauritius

**(Refer Appendix 1 – Standard Specifications)**

### **Special Notes: Electrical and Waterproofing works**

The Bidder is expected to obtain quotation and select specialist contractors registered with the CIDB for the execution of electrical and waterproofing works respectively.

**A. ALUMINIUM WINDOWS AND DOORS****1.0 GENERAL****1.1 Submission**

1. Submit shop drawings
2. Show detailed window assembly, including: large scale details of members and materials, of brackets and anchorage devices and of connection and jointing details fully dimensioned layouts for positioning of brackets and anchorage devices structures, dimensions gauges, thickness, glazing details, description of materials including catalogue members, products and manufacturer's names, aluminium alloy and temper designations, finish specifications and all other pertinent data.

**1.2 DELIVERY AND STORAGE**

1. Adequately protect aluminium and aluminium finishes to prevent damages thereto during fabrication, storage shipping, handling and installation.
2. Deliver, handle and store units by methods approved by manufacturer. Protect from damage and staining.
3. Protect sills and stools after installation with boards heavy paper or other suitable protection, secured in place, to prevent staining or scratching. Do not remove protection before final cleaning.

**1.3 WARRANTY**

1. The contractor shall submit a warranty of five years in writing from the manufacturer.
2. In addition to the above, insulating glass units shall carry manufacturer's standard warranty of minimum five years for defective materials and ten years.
3. The warranty shall include resistance to cyclonic winds of not less than 280 km/hr and water tightness.
4. The contractor shall submit a certificate from a registered professional engineer certifying that Aluminium openings fixed in place shall withstand wind speed of not less than 280 km/hr. This certificate shall in no way waive or diminish the contractor's liability towards the employer.

## 2.0 PRODUCTS

### 2.1 MATERIALS

1. Aluminium extrusions: Shall be for the ALCAN, HUECK, TECHNAL, MUSKITA and ALUNION aluminium or approved equivalent of minimum 25 microns.
2. Finish clean anodized sections natural finish.
3. Bolts, screws and fasteners: Hot dipped galvanized or cadmium plated Steel or 316 stainless steel.
4. Glass: 6.38 mm laminated glass and Naco openings with 6 mm clear glass.
5. Glazing Tape: Vulcanised butyl tape with continuous neoprene spacer, colour as selected by Architect.
6. Setting Block: Neoprene 10 mm long, 80A durometer.
7. Steel: Brake formed, galvanized sheet steel.
8. Aluminium sections to be of minimum 2 mm thk to Architect's approval

## 3.0 EXECUTION

### DESIGN

1. Allow full expansion and contraction of window framing members without causing stress within the window assembly as result of such expansion and contraction.
2. Tolerate structural deflection and distortion structure, under design criteria conditions, without imposing load on window assembly

### FABRICATION

1. Make profiles of framing members as shown on drawings.
2. Entire assembly shall be weathertight throughout.
3. Fabricate complete units in shop to provide minimum tolerance and hairline joints throughout.
4. Assemble members by stainless steel screws. All connections shall be internally sealed in factory with approved sealing compound. Exposed frame sealants are not acceptable.
5. Aluminium extrusions shall be designed to provide sufficient section modules to safety resist imposed loads but minimum thickness of any part of the load bearing extrusion shall be 3 mm. Glazing stops may be 6 mm. Be prepared to submit design data as requested by Architect.

6. Conceal interconnecting members and fasteners in completed assembly.
7. Do not place manufacturer's name plates, labels or any other finished means of identification on exposed of finished parts.
8. Provide weep holes on tubular members to drain and condensation.
9. Glass stops shall provide edge margins recommended by glass manufacturer.
10. Paint all metal surface in contact with concrete or masonry, plastic, mortar or dissimilar metals with protective lacquer or bituminous coating.
11. Mitre and full strength vulcanize joints in weather-stripping.

#### 4.0 INSTALLATION

1. Provide all fastenings or anchors required to be built in under work of other Sections.
2. Use only concealed fastenings.
3. Securely install components so that they line up square in true, straight flat and/or flush planes, plumb and level free from distortion.
4. Make joints neat and fine as practicable. Allow for full expansion and contraction and take into consideration climatic conditions prevailing at time of installation.
5. Fasten galvanized steel supports and clips with galvanized bolts and fasten aluminium members with stainless steel screws and bolts.
6. Ensure that corner joints of frames are weathertight.
7. Clean aluminium and glass surfaces that are to receive glazing materials with an oil removing solvent and wipe dry.
8. Glaze windows with factory glazed wrap around vinyl glazing channels.
9. Place setting blocks at quarter points for each type of glass.
10. Comply with tape manufacturer's recommendations regarding use of spacers for certain glass sizes.
11. Install glass with clean cut edges, leaving spaces to expansion and contraction between edge of glass and inside of frame as recommended by glass manufacturer.



12. Finish tape and glazing wedge with straight unwavering sight lines.
13. Conform to sealant manufacturer's written recommendations for cleaning, priming, backing and joint design to suit type and location of joint and temperature conditions at time of application.
14. Mask adjacent surface likely to become marred with sealant or primer, using non-thermosetting easily removed masking.
15. Apply sealant using pressure operated gun fitted with suitable nozzles approved by the sealant manufacturers. Apply in accordance with manufacturer's directions and recommendations.
16. Apply sealant in such a manner as to assure good adhesion to sides of joints and to completely fill voids in joints. Form surfaces of sealant smooth, concave, free from ridges, wrinkles, sags, air pockets and imbedded impurities.
17. Remove masking tape, soils and sealant which may have been deposited on surfaces near joints.
18. Seal all window frames to adjacent materials both sides.

## 5.0 CLEANING

1. When directed, inspect work and remove protective wrappings, coatings and devices and clean glass and aluminium surfaces. Use methods which will not scratch or damage glass, paint or coatings.

**CERTIFICATE FOR ALUMINIUM OPENINGS**

In accordance with the requirements of (Clauses 1.1 and 1.3) of the Specifications of the contract for the Supply and fixing of Aluminium Openings for the project (Name of Project).....

..... I, the undersigned Registered Professional Engineer, hereby certify that the aluminium openings which have been fixed at (Location) .....

have been designed to resist cyclonic winds of 280 Km/hr.

Name of Engineer:.....

Registration Number with the Council of Professional Engineers:.....

Signature:.....

The following part is to be signed by the Contractor.

In the event of a failure of these openings due to cyclonic winds of 280 km/hr or less, (Name of Contractor) .....undertakes to replace these openings and make good all damages resulting from the failure of these openings.

Name:.....

In the capacity of:.....

Signed:.....

Duly authorized to Sign the certificate for and on behalf of:.....

Date:.....

Seal of Company:.....

## **B. SPECIFICATIONS OF THE WATERPROOFING SYSTEM**

The Subcontractor for waterproofing works must be specialist waterproofing contractors.

### **1.0 The Waterproofing System**

The waterproofing system, unless otherwise specified, shall meet the following performance specifications:

Either

a SSS elastomeric bitumen system in double layers, torched bonded and of total minimum thickness of 4.2 mm with a granular finish, as described below:

- a) The first layer should be a SBS (Styrene – Butadiene – Styrene) elastomeric bitumen system reinforced with non woven glass fibre Md(50 gm<sup>2</sup>) torched applied with a minimum thickness of 1.7 mm.
- b) The second layer should be a SBS (Styrene – Butadiene – Styrene) elastomeric bitumen system reinforced with non woven glass fibre matt having a minimum thickness of 2.5 mm. This layer should have a granular finish colour white for better reflection and applied by torch.

OR

Any other alternative system, provided it is duly supported with all technical specifications and backup information and literature to allow a proper assessment of the treatment proposed.

### **2.0 Performance Specifications of the Waterproofing System**

- 2.1 The system shall, unless specified otherwise, be resistant to foot traffic and light concentrated loads associated with installation and maintenance operations.
- 2.2 The system shall comply with European, South African or American standards.
- 2.3 The system and its installations shall conform strictly to Manufacturer's specifications.

### **3.0 Preparation of surface to receive the Waterproofing treatment**

- 3.1 The waterproofing Contractor shall ensure that the slope of the substrate is adequate to prevent water ponding and is according to Manufacturer's specifications.
- 3.2 All concrete surfaces to be waterproofed shall be reasonably smooth and free from holes and projections which might puncture or otherwise damage the waterproofing system to be applied.

- 3.3 The surface of the substrate shall also be dry and shall be thoroughly cleaned of dust and loose materials prior to the laying of the waterproofing system.
- 3.4 Prior to the application of the new treatment, the waterproofing Contractor shall be required to issue a certificate stating that the surface is ready to receive the new waterproofing treatment and is according to the Manufacturer's Specifications. It is hereby made clear that, should the waterproofing system fails to perform as required, no discharge of responsibilities shall be allowed on the grounds of the existing conditions prior to the application of the waterproofing system.

#### **4.0 Inspection of Waterproofing System**

- 4.1 The waterproofing treatment shall be carried out to the satisfaction of the Architect.
- 4.2 The Contractor shall ensure that the waterproofing system is free from wrinkles, buckles, blisters (trapped air) and other damage. Any damage or defects to the waterproofing system shall be corrected at the Contractor's cost, and to the Architect's approval.
- 4.3 The contractor shall carry out a water test on the finished work, and seek the Architect's approval for the same. The test shall consist in filling the whole treated area with water (after plugging the rainwater pipes outlets) and retaining the water on the treated surface for 24 hours, or as directed by the Architect. Any leak/defect found shall be repaired at the Contractor's cost and another water test carried out to confirm the same, the whole to the Architect's satisfaction.
- 4.4 The contractor shall clean adjacent surfaces of spillage and splatterings of any adhesive materials used in the works.

#### **5.0 Water Test**

- 5.1 The contractor shall allow in his rates for a water test to be carried out after laying the screed to fall, to confirm the absence of any water-ponding. The Test shall be verified and approved by the Architect.

#### **6.0 Guarantee Certificate**

- 6.1 On satisfactory completion of the waterproofing works, the Contractor shall submit a certificate of guarantee against leakage, defective materials and defective installation of the completed waterproofing system. Any such defects or leakage occurring during the guarantee period shall be promptly and completely corrected, including all affected work, at no additional cost to the Employer.
- 6.2 The said guarantee shall be in effect for a period of ten (10) years from the date of the practical completion certificate. The guarantee shall be signed by the Contractor and countersigned by the Manufacturer's representative and shall be submitted to the Employer.

### **C. ANTI-TERMITE TREATMENT**

The anti-termite treatment must create a complete chemical barrier in the sub-structure of the buildings. A 10-year guarantee certificate must be provided to the approval and satisfaction of the Employer.

### **D. PAINTS**

External coating paints shall be waterproof and be guaranteed against discoloration, bacterial growth, cracking, chipping and peeling off from the masonry surfaces for a period of not less than Five (5) years.

All paints, stains and varnishes applied shall be eco-friendly with zero VOCs (Volatile Organic Compounds) or low VOCs (less than 5%).

### **E. TIMBER SPECIFICATIONS**

#### **TIMBER FOR WORKTOPS**

Timber used for all work benches and wall benches (worktops and structural members for both) shall be solid iroko timber of thickness as specified in the drawings of wherever not mentioned. The timber shall be kiln dry and of minimum moisture content of 12%.

The timber used should be guaranteed for a period of 5 years after handing over against warping, cracks, shrinkage and distortion.

All finishes shall be as specified in the drawings and to Architect's approval.

Contractor to include all joineries not specified in the drawings that may be required during manufacture of furniture as per drawing.

Contractor to allow for cutting out of worktops for fixing vulcathene sinks. Care must be taken to have net joints to the satisfaction of the Architect.

Timber used for glazed cupboards shall be sapele or as specified in the drawings.

A Certificate for moisture content shall be submitted to the Architect prior to mass production.

In case MDF boards are specified for the racks, a Certificate of the density of the material shall be submitted as well as damp-proofness.

All drawers, cupboards, lockers and worktables shall have locks as per standard specifications.

Glass panes used shall not be less than 4 mm and samples should be submitted for approval by Architect.

Metal sections shall be hot-dipped galvanized after manufacture, primed and painted as per architect's specifications.

#### JOINERY WORK GENERALLY

All joiner's work generally shall be cut and framed together on the commencement of the works, but shall not to be wedged up or glued until the building is ready for fixing same.

All work shall to be properly, tenoned, shouldered, wedged, pinned, bradded, etc. as directed and to the satisfaction of the Architect and all properly glued up with best quality approved glue. Oval or round brads or nails shall be used for fixing on face work, heads properly mails punched in and the holes filled with putty or as otherwise described.

#### FINISH TO WOODWORK

All exposed faces of woodwork shall be wrot, which shall mean bringing up the surface after planning with sand paper to a smooth satin like finish.

#### DOOR FRAMES AND LININGS

Door frames and linings shall be constructed to the sizes and details shown on the drawings. Joints between style and head shall be mitred.

Fixing irons shall consist of 300 mm long g.m.s hoop not less than 3 mm thick bent up at 75 mm at one end and twice screwed to the frame and the other end built into the walls, and cast into lintols to the depth of 225 mm deep, the straps shall be cut off to the full depth of the lintol.

10 mm diameter galvanized metal dowels shall be fixed to each end of the frames and let into the floor concrete to a depth of at least 50 mm.

Door linings shall be screwed to wooded fixing dovetail shaped and let into the walls and lintol with the same number of fixing irons to frames.

#### DOORS

Doors shall be provided and fixed to the sizes and details shown on the drawings. Doors shall be free from all blemishes and shall be rubbed down to a satin like finish. Framed, ledged and braced doors shall be made to the sizes shown on the drawings and the nailing in construction shall be driven from the face side, the heads of nails shall be punched d the holes filled with putty.

Butts and hinges shall be to the sizes and type specified and be fixed with the full number of screws and on no account shall nails be used.

#### PLYWOOD

Plywood shall be to the specified thickness and shall comply with BS 1455, plywood shall be Grade 1 where varnished and Grade 2 where painted. Concealed side of plywood can be Grade 3. All plywood to be HMR type (High Moisture Resistant). Certificates to be submitted for approval.

#### GLUES

All glues to be used for joinery works shall be the best of their respective kind and shall conform to BS 745,1444,1203 and 1204.

#### SCREWS

Screws to be used for the joinery works shall be brass and shall conform in every respect to BS 1210.

#### NAILS

Nails shall be galvanized mild steel wire nails – all on accordance with BS 1202.

#### MOISTURE CONTENT OF TIMBER

The Contractor is to ensure that the moisture content of the various items if joinery delivered to the site should be at least 12%.

#### SHRINKAGE

The arrangement, jointing and fixing of all joinery works shall be such that shrinkage in any part and in any direction shall not impair the strength and appearance of the finished work and shall not cause damage to contiguous materials or structure.

#### TOLERANCE

Reasonable tolerance shall be provided at all connections between joinery works and the building carcass, whether of masonry or frame construction, so that any irregularities, settlements or other movements shall be adequately compensated.

#### FABRICATION

The joiner shall perform all necessary mortising, tenoning, grooving, matching, tonguing, housing, rebating and all other works necessary for correct jointing. He shall also provide all metal plates, screws, nails and other fixings that may be ordered by the Architect or that may be necessary for the proper execution of the joinery works specified. The joiner shall also carry out all works necessary for the proper construction of all framings, linings, etc. and for their support and fixing in the building.

## JOINTS

The joinery shall be constructed exactly as shown on the Architect's details. Where joints are not specifically indicated they shall be the recognized forms of joints for each position.

The joints shall be made so as to comply with BS 1186, Part 2: 1971.

Loose joints are to be used where provision must be made for shrinkage or other movement acting other than in the direction of the stresses of fixing or loading.

Glued joints are to be used where provision need not be made for shrinkage or other movements in the connections, and where sealed joints are required.

All glued joints shall be cross-tongued or otherwise reinforced.

All nails, sprigs, etc., are to be punched and puttied.

Where glued joints are to be carried out surfaces in contact are to have a good swan of planed finish. All cutting edges of tools are to be sharp to avoid "burnishing". The surface of plywood to be glued should be lightly dressed with sand or glass paper. The sand or glass paper must not be allowed to clog and cause "burnishing".

Members in constriction to be joined by gluing are to be of similar conversion. All surfaces to be glued are kept clean, free from dirt, sawdust, oil and any other contamination.

Adequate pressure should be applied to glued joints to ensure intimate contact is maintained whilst the glue is setting.

Mixing application and setting conditions should be in accordance with the glue maker's instruction.

"Adhesives" for joints in non-loadbearing internal work and for joints in work where the moisture content is always less than 16 per cent can be casein or organic glues.

For work under damp conditions (moisture content normally 20 per cent or more or conditions liable to fungal attack): resin type adhesive are to be used.

## SCRIBING

All skirtings, architraves, plates and other joinery works shall be accurately scribed to fit the contour of any irregular surface against which they may be required to form a close butt connection.

## FLUSH DOORS

Flush doors shall be semi-solid cored and shall be lined on both sides with 4 mm Grade 2 plywood for painting or 4 mm Grade 1 teak plywood where shown.



The doors shall be lipped with 10 mm thick hardwood strips on (4) for sides and shall be fitted and hung to frames as detailed on drawings and specified previously.

Doors shall otherwise conform to BS 459.

## PROCEDURE MEASUREMENTS FOR JOINERY

The Contractor is to take all measurements for joinery works at the building, and not from the Architect's drawings, except where the work is specified to be "built in".

## FIXED-IN-JOINERY

Where joinery works are specified to be "fixed-in" or inserted in the positions, they are to occupy after the surrounding or enclosing carcass has been constructed. It shall be the responsibility of the contractor to ensure that the necessary fixings are incorporated in the carcass. Alternatively, the Contractor shall construct such ground works as are required to provide a suitable base and fixing for the joinery works. The spaces enclosed in the ground works and behind joinery works, shall be filled in solid with plaster. The Contractor is to secure "fixed-in" joinery works so that they are plumb and true to the shapes and dimensions shown on the working drawings and details. Vertical junctions shall be solidly bedded with mortar, wedged or otherwise secured, as may be specified or as is most appropriate in the circumstances, but a clearance is to be maintained in all overhead junctions so that settlements in the building carcass may take place without stressing or otherwise loading the joinery works.

Joinery works shall not be fixed in position until after all floor, wall and ceiling surfaces have been formed or constructed, unless otherwise specified.

## JOINERY ASSEMBLED IN-SITU

Where joinery works are specified to be "assembled in situ" and all stresses of support and fixing are to be engaged in the building, it shall be the responsibility of the Contractor to ensure that the necessary fixings are incorporated in the carcass; alternatively, the Contractor shall construct such ground works as are required to provide a suitable base and fixing for the joinery works.

The spaces enclosed in the ground works and behind the joinery works shall be filled in solid with plaster or weak concrete.

In situ joinery works shall not be executed until after all floor, wall and ceiling surfaces have been formed or constructed, unless otherwise specified.

## DRAWINGS

Work is not to commence until the Architect has approved the manufactured full-size setting out drawings to be provided by the Contractor. Suggestions which the

manufacturer may wish to make modifying the construction and joints shown on the Engineer's drawings will be considered.

#### INSPECTION

Facilities are to be given for the Architect to inspect all work in progress in shops and on the site.

#### TIME FOR DELIVERY

None of the joinery is to be delivered until it is required for fixing in the building. Joinery which does not require to be built in as the work proceeds is not to be brought to the site and fixed until the building is enclosed.

#### TRANSPORT AND PROTECTION

The joinery is to be kept under a waterproof cover during transit and it is to be similarly covered and kept clear of the ground on the site. It is to be handled and stacked carefully to avoid damage.

#### MAKE GOOD DEFECTIVE WORK

Should any shrinkage or warping occur or any other defects appear in the joiner's work before the end of the defects liability period such defective work is to be taken down and renewed to the Architect's satisfaction and any work disturbed in consequence must be made good at the Contractor's expense. Should any shrinkage or warping occur or any defects appear, which cannot be rectified the Contractor shall remove such defective work and replace by new one at his own expense.

### **F. WATER SUPPLY AND WASTES INSTALLATION**

#### PIPINGS

Water supply shall be from the roof water tank already provided by the Main Contractor.

Water pipings for the whole network shall be in UPVC pressure type, rated to withstand a pressure of 10 bars minimum. Dimensions shall be as appropriate, as indicated in drawings, UPVC pipes shall conform to relevant international standards (ISO R 161) BS 4514.

Joints shall be solvent welded by use of appropriate PVC solvent glue. Parts to be joined shall be cleaned first to remove all traces of grease and dirt before being glued together.

Screwed fittings shall be used wherever required to stop valves, flexible pipes etc.

At all user points, except for bib taps, chrome plated ringed flexible pipes shall be used.

Cold water pipings shall be pressure tested to 8 bars at completion of installation works.

A certificated to that effect is to be submitted.

Exposed UPVC pipes at roof shall be painted with anti UV paint and Contractor to include for all fixation above waterproofed roof so as not to pierce through the waterproofing.

Water supply pipings shall be fixed to walls, floorducts, services ducts, furniture panels, etc. by means of colour matching nylon mounting clips at intervals as per manufacturer's specifications.

In addition to the stopcocks provided at each sink unit, appropriate easily accessible stop valves shall be provided in the network so as to enable each laboratory/floor to be isolated independently for maintenance purposes.

## PLUMBING AND WASTES INSTALLATION

### PLUMBING WORKS

- (a) All water supply shall be "polycop pipes" with brass fittings except for underground water supply pipes which shall be "polypipes" with brass fittings.
- (b) All internal water supply pipes shall be concealed in block works.
- (c) Where surface mounted, all water supply pipes shall be fixed with approved clips of the same colour of the pipes.
- (d) Appropriate stop valves shall be provided at easily accessible points so that the toilets and other blocks can be isolated floor-wise in case of leakages and for maintenance purposes. A minimum number of stop valves shall be provided as follows:
  - (i) Entry and exits of all water tanks
  - (ii) Each toilet block
  - (iii) After Central Water Authority Metre
  - (iv) Other blocks and water points

### WASTE PIPES

Waste pipes, waste water (except for laboratory waste) shall be in PVC of the appropriate dimensions and laid to fall 1:100 minimum.

Joints shall be solvent welded by use of appropriate solvent glue. Parts to be joined shall be cleaned thoroughly to remove all traces of grease and dirt prior to joining.

All joints are to be tested for leaks. A certificate to that effect is to be submitted.

PVC bottle traps are to be connected at discharges from wash hand basins and sinks.

All waste pipes are to be connected to catchpits and rodding eyes shall be provided at all changes in direction.

## TESTING AND COMMISSIONING

All piping work is to be done neatly and to the entire satisfaction of the Architect.

Water supply pipes are to be pressure tested to 8 bars pressure and held for at least 8 hours to test for leaks.

Pipes shall be properly supported along walls by means of saddles, PVC clips, etc.

Waste pipes shall be tested for leaks at all joints.

Certificate of testing shall be submitted to the Architect on commissioning.

As-made drawings are to be submitted in 3 copies on commissioning.

## G. GRASS PLANTING

- (a) Clean the whole site, remove bushes, shrubs, plants vegetarian and boulders. Uproot all existing trees trunks and roots, cart away all unwanted materials.
- (b) Level the ground by cutting and filling, bringing the levels as shown on the whole area with heavy roller and make good all depressing by additional imported good soil wherever necessary.
- (c) Supply and spread a layer of 300 mm vegetable soil compacted thickness
- (d) Plant grass 'Chiendent&Bourique' using fertilizer and maintain watering till there is sign of healthy spread over.

**SPECIFICATIONS FOR ELECTRICAL INSTALLATIONS****AT****New Fisheries Post at Case Noyale****1.0 Scope of works**

The scope of works under the present contract shall include but shall not be limited to the following:-

- a) Supply, install, test and commission of distribution boards, & accessories, etc...
- b) Supply, install, test and commission of lighting fittings & accessories, etc...
- c) Supply, install, test and commission of L.T. cables in conduit/trunking.
- d) Supply, install, test and commission of Earthing System, etc...
- e) Supply, install, test and commission of switches, double pole switches, sockets, extractor fan, hand dryer, etc...
- f) Supply, install, test and commission of air conditioning units.
- g) Any associated civil works

**2.0 Instruction to tenderers****2.1 Makes**

Equipment/materials for this project shall be as per specifications/schedules or as indicated on the drawings. Tenderers shall specify clearly the makes of various equipment/materials they propose to use. These shall be accompanied by documentation (preferably in original) to enable the Director (or designated representative) of Energy Services Division (ESD) to approve or otherwise.

The decision of the Director (or representative) shall always be final and no materials/equipment shall be supplied/installed in the project without his approval or that of his representative.

## **2.2 Manner of Execution**

The works shall be executed in the manner set out in the specifications or where not set out, to the satisfaction of the ESD Engineer and all reasonable variations on site shall be carried out in accordance with such directives as the Engineer may give.

Electrical installations shall be carried out to good standards of workmanship and all equipment, materials and fittings shall be new and according to specifications. Where no details have been provided, products shall be manufactured to the British Standards applicable to the particular product.

## **2.3 Site Exigencies**

The selected contractor shall respect security arrangements in force and shall seek necessary permission and security pass for yard access, if any for execution of the work. The contractor shall carry out works outside normal office hours where deemed necessary and authorised by ESD Engineer without any increase in contract cost. Claims for overtime works shall not be entertained. The site shall be kept tidy and no materials/refuse shall be kept which may cause obstructions.

For any information, please contact Mr S.Boodoo, Electrical Engineer/Senior Electrical Engineer, Energy Services Division, 2<sup>nd</sup> Floor, NPF Building, Rose Hill, Tel No: 454-5032.

### **3.0 Conditions of Contract**

#### **3.1 Site Visit**

Bidders are advised to visit the sites before submission of bidder so as to be fully acquainted with the nature of the site and extent of work involved.

#### **3.2 Price Activity Schedule & Schedule of Materials**

The bidders shall fill in the, Priced Activity Schedule and submit same with the bid documents.

This schedule has been prepared with a view to provide a common basis for tendering. Before submission of tender, it is deemed that the bidder has acquainted him with all conditions prevailing on site. All the drawings, specifications and Priced Activity Schedule are complementary and should be read accordingly. The Bidders are advised to carry out measurement and check the quantities of materials.

In case of discrepancies, omissions or errors, the bidder shall inform the Director of the ESD prior to submission of the tender. No extra claim shall be entertained afterwards on this issue.

#### **3.3 CEB Supply**

The contractor shall liaise with representatives of the CEB for connection of a new power supply. The successful tenderer will take delivery of CEB meters and will allow for all that is necessary to erect, support and connect these instruments. The contractor will allow in the Priced Activity Schedule for assistance to the CEB for connection to the switchboard.

#### **3.4 Guarantee Period**

The electrical installation shall be guaranteed against manufacturing defects, bad workmanship and other defects not related to normal wear and tear for a period of one year from date of successful commissioning in presence of representatives of ESD.

In the event of a defect, the Contractor shall at his own expense, within 48 hours, make good such defects as instructed to the satisfaction of the Engineer.

### **3.5 Provisional /Contingency Sum**

Provisional/ Contingency sum included in the contract price shall be expended or used as the Engineer may in writing direct and not otherwise. In so far as the provisional/contingency sum included in the contract price is not expended or used, it shall be deducted from the contract price.

### **3.6 Programme of Work**

The tenderer shall clearly indicate in the offer the time period for the execution and completion of the installations for the whole project.

### **3.7 Retention Money**

A fraction of the contract value (5%) shall be retained after successful commissioning and shall be released at the end of the one year guarantee period, subject to maintenance being carried out satisfactorily during that period.

## **4.0 Technical Specifications**

### **4.1 Electrical Installations**

This section provides a brief description of the electrical works related to this contract. The selected Electrical Contractor shall carry out the works to the full satisfaction of the Chief Engineer of ESD or his representatives.

### **4.2 Regulations**

The installations shall conform in all respects to the Institution of Electrical Engineers (U.K.), 17th Edition Wiring Regulations (BS 7671-2008) with subsequent amendments.

### **4.3 Electrical Supply**

The new installation shall be furnished with single-phase 230V, 50Hz power supply derived from a CEB source.



#### **4.4 Electrical Panels**

The distribution boards (DBs) shall be to IP 559 and shall be of galvanised steel with polyester paint finish, hinged lockable door. The panel shall be big enough to accommodate incoming and outgoing feeders and the following:

1. MCCBs/MCBs, and RCBOs as per schematic layouts.
2. Copper Earth Bar Terminal with suitable number of outlets & sizes.
3. All accessories to make a complete panel.

The distribution boards shall be wall mounting. All distribution boards shall be of minimum 25 kA breaking capacity. Lower kA ratings shall not be acceptable.

All circuits and instrument in the board shall be properly labelled with perspex and danger notices fixed on panels. Plasticised schematic layout shall be fixed in respective Distribution Boards.

Panels shall be located as shown in drawings and shall be properly earthed. 30% of spare capacity shall be allowed. There shall be ample space in the panel to allow for easy access when required for manual work.

#### **4.5 Moulded Case Circuit Breaker (MCCB), Miniature Circuit Breaker (MCB) and Residual Current Breaker with Overload (RCBO)**

##### **4.5.1 Moulded Case Circuit Breakers**

Moulded Case Circuit Breakers shall be fixed type fitted with trip free manually closing mechanism. They shall be designed and tested to B.S 4752 and shall be provided with an inverse time delay and adjustable thermal release (0.7/1 In) as well as necessary accessories. The trip devices shall be direct acting. They shall be of the single break type and shall have a minimum breaking capacity of 25 kA. It shall also incorporate the following:

- (i) positive opening indication
- (ii) test button for mechanical release control
- (iii) adjustable earth leakage module (0.03 A – 3 A) shall be fitted only where specified.

#### **4.5.2 Miniature Circuit Breakers (MCB)**

MCB's shall be of reputed make and break type with trip free mechanism to IEC EN 60898. They shall be equipped with non-adjustable thermal overload and magnetic short circuit release with a minimum breaking capacity of 6 kA.

#### **4.5.3 Residual Current Breaker with Overload (RCBO)**

RCBO's shall be of the current type to IEC EN 61009. It should be as rated in the schematic with a minimum breaking capacity of 6 kA. The RCBO should be provided in one and the same unit.

#### **4.5.4 Photocell Switch**

The photocell switch in the electrical distribution boards shall be programmable type and will be used for controlling external lighting and floodlights. The external sensor should be rated IP65.

An Override switch should be provided to enable bypassing of the photocell switch function whenever necessary. The circuits shall be able to drive a double pole contactor unit rated at 20A, 230V as shown in schematics.

### **4.6 Type of Installations**

The installation is designated to be of *Concealed Type*. PVC conduit pipes of yellow or orange colour complying with the relevant British Standard shall be used. The conduit shall provide adequate mechanical protection for the enclosed cables. Cut ends of conduits shall have no burrs left to avoid damage to the insulation of conductors while pulling them through. Conduits shall be installed from point to point using suitable drawing-in or loop-in boxes. Joints shall not be allowed.

The laying of conduits shall be such that any condensation inside the conduit is drained out. The casting of conduits in concrete shall be laid in such a way that will prevent any movement when the concrete is being cast. The conduit shall be securely tied with the reinforcement. The conduit shall terminate into end and loop-in boxes which shall also be tied securely with the reinforcement and these shall be so positioned that after the concrete is cast and the shuttering removed, the boxes are flush with the concrete.

#### **4.7 Conduit in Blockwork**

When the conduits are to be recessed in concrete blocks a chase shall be made in the concrete block. The conduit shall be properly secured in the chase which shall be made good afterwards.

#### **4.8 Inspection Boxes**

Suitable inspection boxes to the nearest minimum requirements shall be provided to permit periodical inspection and to facilitate replacement of wires if necessary. The inspection/junction boxes shall be mounted flush with the wall or ceiling concrete. Suitable ventilating holes shall be provided in the inspection where required.

#### **4.9 Fish Wire**

To facilitate drawing of cables in the conduits fish wire 18 swg shall be provided along with laying of recess conduit, the entire conduit system including those for outlets and boxes shall be thoroughly cleaned after completion of erection and before drawing of cables.

#### **4.10 Cabling & Wiring Works**

Single core PVC insulated 600V grade copper conductor manufactured in accordance with BS 6004, shall be used for wiring inside conduits for internal wiring.

Main and submain cables shall be generally of 1 kV grade conductor of high conductivity copper wires insulated with PVC.

The armoured underground cables shall be routed through yellow/orange high pressure PVC pipes in trenches as per drawing. They shall run in continuous lengths; no cable joint shall be permitted. The contractor shall make all necessary allowance in his quotation for any trenching work which shall include excavation and backfilling as well as erection of pits.

Cables shall comply with relevant BS and Mauritian Standards. Conduit of adequate dimension shall be used where necessary in order to satisfy cable space factor.

IEE standard colour code shall be observed.

#### 4.11 Lighting Installations

All luminaires shall comply with BS 4533 and supplied and installed complete with their lamps and control gear as specified. All tube lights shall be complete with tube, electronic starters and p.f. compensating ballast. All luminaires shall be carefully stored before erection and prior to hand over any damaged paintware shall be made good of and the whole luminaire cleaned.

Luminaires shall be in accordance with the schedule given below:

Type	Description
A	Indoor fluorescent fitting with louvres which shall be complete with 2x28W linear energy saving fluorescent tube (4ft) with high frequency gear.
B	Waterproof fluorescent fitting to IP 65 which shall be complete with 1x28 linear energy saving fluorescent (4t) with high frequency gear.
C	Watertight and impact resistant circular bulkhead fitting wall or ceiling mounted with polycarbonate diffuser complete with 2 x 9 W EF lamp with integral control gear to IP 65.
D	LED Floodlight with the following characteristics <ul style="list-style-type: none"> <li>• Die-cast shell/Aluminium alloy body</li> <li>• strengthened safety glass</li> <li>• Safety rating: IP65</li> <li>• Light angle: 25° to 120°</li> <li>• Power:24W</li> <li>• Voltage rating: 230V</li> <li>• Efficiency: at least 80%</li> <li>• Total Lumen output: about 17,000 lumen</li> </ul>
E	Emergency light units which shall be of non-maintained type- AC 230 V/50 Hz. Emergency duration of 3 hours. Complete with 8 W Fluorescent tube and with lamp output of 140-200 Lumen. With Sealed rechargeable Nickel-cadmium battery inclusive of battery charger and charging monitor LED. To IP 42 Class II. Accessories for base mounting shall be included.
F	Sphere Garden Bollards('Boule de Neige') which shall be to IP54 with the following features: <ol style="list-style-type: none"> <li>(i) Opal diffuser in polycarbonate</li> <li>(ii) Dimensions: <math>\phi</math> 400mm</li> <li>(iii) 2 x 18W EF lamp</li> </ol>

Type	Description
	Appropriate fitting shall be provided to hold the light.
G	Pendant luminaire with aluminium body and refined aluminium reflector. To IP23, IK07. Integral control gear. Fitted with 40W fluo compact lamp. To be suspended from ceiling using manufacturer's suspension kit consisting of stainless steel wire cable and accessories. The height of the luminaire shall be about 3m above ground floor level.
H	Waterproof fluorescent fitting to IP 65 which shall be complete with 1 x 14 W linear energy saving fluorescent with high frequency gear.

The types A & B lighting fittings required on this project shall be fitted with energy saving fluorescent tubes (4ft).

The energy saving fluorescent tubes (4ft) shall comply with the following:

- Standard T5 fixtures
- Mains Voltage/frequency: 230V+/-6%, 50Hz
- Power factor >0.98
- Low harmonic distortion <20%
- Lumen: About 2600 lumens
- Life span: about 15,000 hours
- Colour of Light: white
- Reversible retrofitting
- Operation frequency of the tube >35kHz
- Colour rendering – Ra >85

The energy saving fluorescent tubes shall be CE certified. All required adapters/accessories shall be provided.

All luminaires shall be manufactured to British or European Standards

#### **4.12 Switches & Sockets**

Switches (10 A rated) and switch sockets (13 A rated) shall be to relevant British or European standards (BS 3676) and shall be of the white insulated pattern. They shall be flush mounted in suitable boxes. The number of gang and ways shall be as indicated in the drawings. The lighting switches and sockets shall be fixed at 1500mm and 900mm respectively above the finished floor level or as instructed. They shall be of reputed make. All sockets should be with neon indicator.

All outdoor electrical fittings and accessories shall be weatherproof and vandalproof.

#### **4.13 PVC Conduits/Pipes**

Wherever specified on the drawings (site plans) yellow or orange PVC pipes pressure type of the size specified shall be provided for underground cabling. These shall be laid as specified.

#### **4.14 Man Holes**

Manholes shall be provided wherever specified and shall be with flush and watertight covers. Dimensions are specified on the drawings.

#### **4.15 Labels and Danger Notices**

All main circuits and subcircuits shall be clearly and neatly labelled for quick circuits identification. A schematic layout for each distribution shall be displayed in each distribution Board.

Suitable warning notices in red lettering on white background shall be provided on each distribution boards. Label shall bear identifications on drawings and voltage also.

Suitable "Danger" plates shall be securely affixed on the distribution boards and mounted in prominent position. Each danger notice shall be fabricated in enamel sheet steel. Symbols shall be in red on white background and shall be to British Standard.

#### **4.16 Earthing System**

The main distribution board shall be provided with a local earthing system. This shall comprise of at least 3 copper-clad steel earth rods/plates with dia 16mm buried to a depth of 2400mm at 5m intervals as shown in the diagrams. The interconnecting copper cable between the earth terminal of the distribution board and the earth rods shall be sized in accordance to IEE Regulations.

The earth loop impedance at any point of the installation shall not exceed five ohms. Concrete inspection pits c/w hot-dipped galvanised lids shall be provided, subject to Energy Services Division approval in order to facilitate inspection and testing.

#### **4.17 Specifications for Extract Fans**

Extractor fans shall be to the following specifications:

- wall/glass mounted with dimensions 200 - 300 mm
- steel protected by polyester spray paint
- single phase 230V 50Hz
- Air flow rate of about 250 m<sup>3</sup> /h
- motor/electrical connection protected to IP 55
- automatic external shutters to prevent ingress of water
- easily removable safety grille for maintenance/servicing
- noise level shall not be greater than 50 dBA at one metre. The tenderer may be required to submit the necessary test certificates
- wired remote switch for fan speed control.

One socket (one gang) with neon shall be located near each extractor fan. The tenderer has to include the latter in its offer.

The extractor fans shall be connected to the respective lighting switches.

#### 4.18 Hand Driers

Hand Driers shall be installed to the following specifications

- *Rating 1.5 kW, 230 V ac, 50 Hz complete with all accessories including switch socket and plug to BS.*
- *Fan: highly efficient and low noise fan*
- *Automatic 'no touch' start and stop*
- *Drying cycle : 30*
- *Safety features*
  - (i) Fitted with safety devices to protect heating unit and fan motor against overloading*
  - (ii) Fitted with 40 s timer to prevent the drier running continuously in the event of the sensors becoming obstructed*
  - (iii) Incorporating hair/face drying facility*
  - (iv) Outer casing: plastic*

#### 4.19 Wall fans

- Single phase operation, 230 V, 50 Hz
- Blade diameter to be 18 inches.
- With complete metal base and casing
- To British Standard and European Standards
- Three speed operation with integral control and pull cord switch
- Fan motor shall be aluminium capacitor motor
- Paint finish to be in brilliant black
- Complete with all accessories including control switches

One socket (one gang) with neon shall be located near each wall fan. The tenderer has to include the latter in its offer. All wall fans shall be fixed securely with fischer.



#### 4.20 Ceiling Fan

Ceiling fans shall feature the following:

- Single Phase operation @230V, 50-HZ
- To be suspended securely using custom-made 300mm long downrod
- Blade diameter to be 900mm
- Two-speed operation with controls fixed on wall at 1800mm above FFL
- Fan motor shall be aluminium capacitor motor
- Paint finish to be in brilliant white epoxy

#### 4.21 Air conditioning units

##### Split and Wall Mounted type

The Air Conditioning Units shall be of the **DC Inverter Type** and to the specifications given below. The Capacity and location of the proposed units are shown in drawings.

##### 4.21.1 Air Conditioner Characteristics:

###### *Indoor Unit :*

- ◆ Wall mounted type.
- ◆ Horizontal/vertical air flow.
- ◆ Low noise level at high speed (**less than 52 dBA at 1m from the unit**).
- ◆ Automatic air deflection.
- ◆ Variable fan speed and temperature control.
- ◆ wireless remote control with LCD temperature display and holder.
- ◆ One touch air filter (down to 0.01 micron).
- ◆ Slim, compact and of elegant design.

###### *Outdoor Unit:*

- ◆ Shall be suitable for tropical climates.
- ◆ Shall be weatherproof, cyclone proof.
- ◆ Rotary type compressor with five years guarantee.

#### **4.21.2 *General Notes***

1. The price quoted shall include supply, installation (inclusive of civil works) and commissioning of the air conditioning unit.
2. Original leaflet containing technical data shall be attached as proof of compliance with specifications. Make and country of origin of the unit quoted shall be specified as well as the country of final assembly.
3. The compressor of the air conditioners shall be guaranteed for a period of at least 5 years and all other parts for a period of at least 1 year. This guarantee period shall be effective only as from the date of successful commissioning of the air conditioners.
4. The split type air conditioners shall be equipped with wireless remote controls by means of which the air conditioners may be switched on and off, the temperature and fan speed may be controlled and from which one may read the room/office temperature via an LCD display.
5. Any supports, mounting brackets etc... (To be hot dipped galvanized) shall be supplied and installed by the successful tenderer.
6. The position of the indoor units may be subject to change at the moment of installation and this shall be considered by the tenderer when quoting. Note that no variation will be accepted upon this item after award of the contract.
7. The outdoor units shall be installed on galvanized brackets to be fixed on the wall.
8. Any civil/masonry works ( e.g. drilling of hole in order to pass the pipe or ductwork, modifications to window panes/frames/metal work as and if deemed necessary by tenderer) associated with the installation of the air conditioner shall be undertaken by the tenderer who shall make a site visit before quoting. All openings shall be properly sealed to avoid leakage of cool air.
9. The successful tenderer shall have to take all the necessary precautions so as not to damage the flooring, painted block work during execution of the works.
10. Successful tenderer shall have to make their own arrangements for scaffolding and any other materials required for the installations.
11. The air conditioners shall be provided with a suitable drain pipe with sufficient slope for perfect drain. The drain pipe shall be leak proof and shall be securely fixed as and where necessary up to 50mm to soil level.
12. All piping (refrigerant and drain) shall be enclosed within white PVC trunking of suitable dimensions indoors and outdoors. Note that the cover of same shall be

- securely fixed so as not to be blown away by cyclonic gusts. Moreover, all joints shall be suitably sealed by means of silicon rubber.
13. The air conditioner shall be equipped with appropriate valves along the refrigerant pipes so as to allow isolating and separating the indoor unit from the outdoor unit without any loss of refrigerant which shall be ozone friendly. Tenderers are hereby requested to indicate clearly in their quotations whether or not the air conditioner they will be proposing will be equipped with the said valves or some other device which will achieve the same function.
  14. Any opening shall be properly sealed in order to prevent leakage of cool air and ingress of rain water especially during cyclonic periods.
  15. Electrical supply shall be provided from a control switch of appropriate rating. The cable from indoor units to outdoor units shall pass through conduits of appropriate size. Prospective tenderers shall also have to provide for these items in their tenders.
  16. The tenderer shall submit as part of the contract, upon completion of works, **two copies** of the operations and maintenance manual inclusive of an exploded diagram of the air conditioning plant showing the different parts and associated part numbers.
  17. The tenderer shall test and commission the whole works in the presence of the Client and the Energy Services Division or their representatives. During testing, the sound pressure level shall be measured. Two copies of test certificates shall be submitted together with the one-year guarantee certificates.
  18. The commissioning of the air conditioning installation works shall be deemed complete and successful only when all the above have been satisfied and completed.
  19. The tenderer shall provide free servicing on a quarterly basis during the one-year guarantee period. Such servicing shall consist of cleaning of filters and checking the performance of the units. Quarterly reports shall have to be submitted to the Director, Energy Services Division and representatives of client.
  20. A fraction of the contract value (5 %) shall be retained and shall be released after the one year guarantee period, subject to full compliance to the proposed servicing scheme.

## 4.22 Generator set

### Output rating

Rated for continuous duty

At least 10 kVA at 0.8 power factor, single-phase, 230 V

50 Hz, 1500 rpm

### Method of operation

The control shall give fully automatic mains failure operation, so designed that the plant will on 6% reduction of voltage on any phase of the supply, automatically take over the load and will continue to carry out the load until 0-15 minutes after the mains supply has been fully restored. The plant will then close down transferring the load back to the mains ready for the next mains failure.

### Electrical set-up

The Automatic mains failure control panel shall be housed in the generator but the changeover device and ancillaries shall be mounted in a wall cabinet. The 2-pole contactors for the mains and the alternator shall be of the magnetic blow-out type and of robust construction. The contactors shall be rated for the full load of the generator set. The contactors shall be provided with relays and auxiliary contacts, and shall be electrically and mechanically interlocked.

### Engine

Heavy duty four stroke **water cooled diesel engine** running at 1500 r.p.m, fitted with tropical radiator and constant speed governor and suitable for diesel fuel available locally. Injected and turbocharged.

### Alternator

Single bearing 4 pole brushless type, screen protected, drip proof, self excited and self regulating, Insulation class H, rated for continuous duty and be able to sustain without damage an overload of 200% continuous rating for 10 seconds.

### Automatic voltage regulator

A fully solid state, static type, automatic voltage regulator unit shall be provided. It shall incorporate voltage control circuitry, static build up of voltage, frequency compensation circuitry and isolation transformers to reduce surges. Voltage regulation shall be +/- 1% r.m.s. from no load to full load with +/- 5% frequency change and +/- 20% ambient temperature change.

**Overload Capacity**

A 10% overload for one hour in twelve hours run.

**Sound attenuation**

The complete set should be factory fitted with a sound proof canopy which ensures a sound level of 76 dBA when measured at one metre. Weatherproof and acoustically insulated enclosure shall be fitted to the generator set off the base frame. Enclosure shall include side access doors, residential type silencer via flexible coupling, ventilation baffles, and acoustic louvers. Enclosure shall be able to withstand local cyclonic conditions. All doors/openings shall be lockable and be of stainless materials. Manufactured certified copy of noise attenuation shall be submitted with the tender.

**Exhaust System**

Residential silencer of stainless steel inclusive of piping, brackets, bends and weatherproofing shall be provided. The exhaust pipe shall be supported by means of hot-dipped galvanised steel brackets and bolts placed at regular intervals of not more than 500mm. The pipe shall run up to 1000mm above the roof level of the generator room.

The tip of the exhaust pipe shall be suitably protected against the ingress of water in rainy and cyclonic weather and drain plugs shall be provided at suitable points on the silencer and exhaust pipe.

**Batteries**

Heavy duty lead acid starter batteries complete with stand. The batteries shall be maintenance free type. They should be capable of at least 12 successive starts. A test kit (inclusive of hydrometer) for battery fluid should also be provided.

**Engine filtration system**

The engine shall be complete with fuel and lubricating oil filters with replaceable elements.

### **Earthing system**

The generator shall be provided with its own earthing system and shall read an absolute value of **not more than 2 ohms**. The system shall consist of at least three copper-clad steel rods of minimum diameter 16 mm buried to a depth of 2400 mm in a straight line at intervals of 5000 mm. The rods shall be linked by single core solid copper cable which shall be appropriately terminated and selected.

### **Fuel storage and supply**

#### **(a) Engine fuel tank**

The generator shall have an inbuilt fuel tank with level indicator for **at least 8 hours running** at full load. The tank shall be complete with level indicator, breather, strainer, drain plug, feed and return lines and inlet connection with gate valve for filling from bulk storage tank. The tenderer must fill in completely the tank at time of commissioning and has to include such costs in its offer.

#### **b) Control Panel**

The generators shall be provided with an automatic mains failure control panel (set mounted), to supply the load on mains failure to retransfer the load upon restoration of mains and stop after a preset delay. The supply shall be automatically interrupted after failure on any phase or fall in voltage below legal limit.

The set mounted control panel shall include the following:

- (i) A set of electrically and mechanically linked 4 pole change over contractors.
- (ii) One circuit breaker with adjustable magnetic and overcurrent release for generator protection.
- (iii) Adjustable earth leakage circuit breaker covering range of 30mA to 500 mA.
- (iv) Three-attempt start
- (v) Fault and shut down with indicator lamps for:
  - (a) Alternator overload
  - (b) Engine overspeed

- (c) High engine temperature
- (d) Low oil pressure
- (e) Low alternator volts
- (f) Fail to start
- (g) Mains operated battery charger and engine operated battery charging alternator with charging ammeter
- (h) Start control switch, emergency stop button, manual start push button, indicator for plant on load and mains on load.
- (vi) Instruments indicating the following:
  - (a) Oil pressure
  - (b) Water temperature
  - (c) Battery charging rate
  - (d) Voltage on each phase and between phases
  - (e) Amperes on each phase
  - (f) Frequency
  - (g) Hours run

### **Concrete platform**

Civil works for construction of a concrete base to support the generator sets shall form part of the contract. The base shall be of suitable sizes with an outside dimension exceeding that of the generator set by a minimum of 305 mm on all sides. The minimum thickness of the base shall be 150 mm. Cost for the construction of the concrete platform shall be included in the tenderer's offer.

### **Generator Testing**

On completion of the installation of the generator the successful tenderer shall carry out tests on the generator in the presence of ESD representatives.

A set of test certificates shall be supplied showing performance of the generator at no load, 50% load and 100% load. Insulation test and earth continuity test shall also be carried out and the earth resistance measured.

Testing and measuring equipment shall be very good quality and shall be provided by the contractor in all cases.

**Drawings and Manuals for generator**

The following shall be submitted:

- (i) One-line diagram of installation.
- (ii) Operator's manual (Operation and Maintenance Manual).
- (iii) Complete workshop manual for engine overhaul. The workshop manual must include exploded and labelled diagrams showing all parts of the engine as well as a complete list of spare parts with part numbers.
- (iv) Circuit diagrams of the automatic mains failure control panel and electrical components on the engine.
- (v) Manual and circuit diagram for the alternator.
- (vi) Manual for the batteries.
- (vii) Recommended spare parts list with part numbers for 2 years' running.

All of the above shall be given in three sets.

**Spare Parts**

The following shall be supplied:

- (i) Spare air filters for two servicings
- (ii) Spare oil filters for two servicings
- (iii) One spare Automatic Voltage Regulator ( AVR )

**Note:-**

Bidders shall provide along with their offer equipment catalogues, schedule of proposed materials and a full set of drawings (to scale) of proposed layout with details of diesel tanks, exhaust system, ventilation system etc.

**Tools**

Tenderers shall submit a complete list of tools as recommended by the manufacturer. The following are the minimum requirements:

- (i) Set of spanners
- (ii) Set of screw drivers
- (iii) Set of pliers
- (iv) Set of Allen keys
- (v) Hammer
- (vi) Wrenches
- (vii) Clamp on Multimeter
- (viii) Earth loop impedance tester



## **4.23 Fire extinguishers**

### **4.23.1 Dry powder**

Dry powder fire extinguishers shall be of ABC type, of capacity 4.0 kg and at a working pressure of at least 14 bars.

The cylinders shall be of light weight corrosion resistant design. The carrying handle shall be one metre off the floor level.

### **4.23.2 Carbon dioxide gas**

Carbon dioxide gas fire extinguishers shall be at a working pressure of at least 56 bars and contain 2.0 kg of carbon dioxide.

The cylinders shall be of light weight corrosion resistant design. The cylinders shall be of robust aluminium construction. The carrying handle shall be one metre off the floor level.

## **4.24 Testing & commissioning**

Upon completion of the installation or part of it, the Contractor shall test and commission plant, equipment and integral systems, in stages if required, to ensure that it is intrinsically safe, in proper working order and capable of performing its functions in accordance with the specifications and to the satisfaction of the ESD.

Tests shall be carried out in the presence of the Director, ESD or his representative on all sections of the installation work and three duly signed certificates of test results shall be submitted to the Engineer.

The following tests shall be performed:

- (a) Earth impedance
- (b) Insulation resistance on main and sub-main cables prior to connection.
- (c) Operation of protective devices
- (d) Earth continuity test

If the installation fails any of the above tests, then any previous tests already carried out and affected by the remedial work required must be repeated. Arrangements for testing including supply of test equipment shall be the responsibility of the Contractor.

Testing and measuring equipment shall be of very good quality and shall be provided by the contractor in all cases.

All test certificates and as fitted drawings shall be approved and signed by a **Registered Professional Electrical Engineer** (which can be employed on a part time basis by the contractor) before submission to the Client.

The installation shall be considered complete only after the following have been carried out:

1. Completion is reported in writing to the ESD representative.
2. Defects pointed out by ESD have been made good.
3. Three copies of Accurate as fitted drawings have been delivered to the ESD.
4. Completion and test certificates have been submitted and found satisfactory by the Director, ESD or his representative.

#### **4.25 Drawings**

The tenderer shall submit upon completion of the works, three copies of as "fitted diagrams"

- (i) the electrical installations and protective gears
- (ii) schematic layout of circuits
- (iii) location of Distribution Boards & cable routes
- (iv) Earthing System

to the Director of the ESD or his representative.

**SPECIFICATIONS FOR MECHANICAL INSTALLATIONS****AT****New Fisheries Post at Case Noyale****1.0 Scope of Works for Mechanical Services**

The scope of works for Mechanical Services installations for at the new Fisheries Post at Case Noyale shall include the following:

- (i) Cold water system
- (ii) Hot water system
- (iii) Waste and sewage system
- (iv) Irrigation reticulation
- (v) Associated civil works

The contractor shall supply, install, deliver, test and commission each of the above works to the full satisfaction of the Mechanical Engineer.

The contractor shall ensure that he delivers a complete installation in working order and which suits the specifications defined herein and which shall conform to the latest relevant British Standards or other recognized international standards.

These documents are meant to be a general guide to the Contractor and are not meant to replace applicable codes of practice and regulations, nor shall they provide him with any excuse for claiming additional costs and for not executing the job to the full satisfaction of the Mechanical Engineer. Where details have not been provided, the works shall be effected according to good Engineering design and practice. Any discrepancy or other irregularity shall be notified to the Mechanical Engineer immediately for any rectification.

The tender drawings and schematic layout submitted with these specifications are intended to provide the contractor with the design concept and illustrate the general layout of all equipment and distribution systems. These, together with the specifications give sufficient information to enable the contractor to estimate the cost and to determine how the system must be installed, tested, operated, serviced and maintained.

Locations and dimensions shown in the drawings are only indicative routes and zones in which the above mentioned mechanical services must be installed. All mechanical installations executed on site shall be as per Contractor's detailed shop drawing duly approved by the Mechanical Engineer.

"As Built" drawing shall be submitted by the contractor on completion of the works. The works shall not be certified as being complete unless these drawings and all required Operating, Maintenance manuals and technical leaflets have been submitted.

## **2.0 Cold Water System**

**2.1** The contractor shall liaise with the CWA for connection and installation of a new water supply.

### **2.2 *Reticulation System***

Water from the incoming CWA mains shall be fed to a fiberglass/polyethylene potable water storage tank installed at ground level. The incoming CWA mains shall also bypass the storage tank and be directed to the ground floor cold water distribution system to supplement the gravity feed from the roof tank.

Cold water from the ground storage tank shall be pressurized by a booster pump set located in the pump room to distribute the roof water tanks, solar water heaters and all draw-off points located at first floor level and dedicated points at ground floor level.

Ground floor shall normally be serviced by the incoming CWA mains supplemented by gravity feed from the roof tanks. In case of insufficient water pressure from either of these sources, the gravity feed may be pressurized by opening the isolating valve located at roof level which shall be normally remain closed. This same valve shall also enable the whole cold water system to be serviced by gravity/CWA in case of pump failure.

The distribution system shall be able to minimize the use of the booster pumps by making maximum use of CWA mains pressure and also cater for water supply during maintenance works on the storage tank and booster pumps.

### **2.3 Cold Water Pipework**

The scope of plumbing installations for cold water system shall include but not limited to the following:

- Inlet connection from CWA mains to the 4500 L cold water storage tank.
- Suction pipe work from storage tank to water pump set installed in pump room.
- Provision of outlet to drain the water tank for cleaning purposes.
- CWA mains bypass connection to ground floor supply.
- Connection from pump outlet to supply manifolds, roof water tanks, solar water heaters and thermostatic mixing valves.
- Connection of roof tank to draw-off points.
- Connection from manifolds to draw-off points.
- Irrigation reticulation network

### **2.4 Cold Water Pipes**

2.4.1 Underground and CWA cold water pipework buried in dedicated trenches shall be High Density Polyethylene (HDPE) complete with electrofusion welded joints and transition fittings rated at a nominal pressure of not less than 16 bar and shall conform to BS 6437 and manufactured to MS ISO 4427, DIN 8075, ISO 161 A.

2.4.2 Surface mounted cold water pipes to draw off points shall be of uPVC pressure type rated at nominal pressure of not less than 16 bar and shall be in compliance with BS 4514, ISO 150 R 161 and manufactured to MS 150 4422-2.

2.4.3 Concealed pipes from manifolds to user points passing in slabs and block walls shall be single length 16/12mm PE-X 95 sleeved in 32 mm isorange conduits. The PE-X pipe shall be Cross-linked Polyethylene and rated to withstand at least 95°C at 10 bars.

### **2.5 General Requirements**

Appropriate fittings as per pipe manufacture's recommendation shall be used for each type of pipe.

All pipes passing through masonry, concrete walls or slabs, shall be provided with PVC sleeves one diameter greater to allow for removal and enable expansion or contraction of the pipes.

No joints or fittings to be allowed in concealed and inaccessible locations.

PVC pipe ends shall be cut square, reamed, chamfered, free from burrs and cleaned with PVC cleaner prior to solvent weld with appropriate glue.

Sufficient numbers of unions shall be utilized to enable dismantling of sections of pipe work during maintenance and at least one tap connector shall be used at each valve to enable its easy renewal.

Each sanitary appliance shall be fitted with individual isolating valve.

Quarter turn isolating valves shall be provided at main branches so as to isolate the system in the event of maintenance and repairs.

Automatic air release valves and water hammer arrestors shall be used as required.

Individual isolating chrome plated angle valves and or full bore mini ball valves in brass and nickel plated body together with chrome plated flexible pipes of appropriate length shall be provided at each interior outlet to WHB/ sinks/ WC cistern and any other sanitary appliance.

All valves, pipeline fittings, and ancillaries shall be of high quality to BS 1010/BS EN 1254 and be similar to SOPHIRER series, WRAS approved and or equivalent.

PE-X pipes, fittings pipe joints shall be according EN ISO 15875-1,2,3 and in conjunction with EN ISO 15875-5,7 and shall be WRAS or other recognized approval bodies.

Pipe work shall be properly and solidly supported along their whole lengths at intervals as specified by the manufacturer. Appropriate clips, galvanized saddles, galvanized hangers with tubular clamps, etc. shall be used for that purpose. All fasteners, screws, nuts washers shall be corrosion proof either of stainless steel 316.

The supports, hangers, etc. shall permit expansion and contraction of the pipes.

Pipe work shall run in a neat manner and installed plumb, straight, symmetrical and at right angles to or parallel to adjacent walls.

All valves, vents and accessories must be fitted in such a manner that they are accessible for operation and maintenance. Valve operating handles must be easily accessible and operation must not be impeded by structure or other services.

All external exposed pipes shall be painted with UV resistant paint and prior to applying finish background paint.

The whole pipe work shall be pressure tested to 8 bars in accordance with BS 6880-3 and BS 6700 and a certificate to that effect shall be submitted to the Mechanical Engineer.

## **2.6 Water Tanks**

One unit fiberglass/polyethylene potable cold water tank of 4500 litre capacity shall be installed on reinforced concrete base/platform as per Engineer's details at ground level. Two additional fiberglass/polyethylene tanks of 1000 litre capacity each shall be installed at roof level.

Installation works shall include all necessary stainless steel anchors, screws, bolts, nuts and washers, hot dip galvanized brackets, guy wires etc. and shall withstand cyclonic conditions.

### **2.6.1 Drain Outlets**

All tanks shall be provided with full bore drain outlet pipe with screwed cap and heavy duty quarter turn valves to allow draining of the tanks for cleaning purposes.

The ground water tank drain outlet shall discharge into storm drain, soakaway or other suitable location.

## **2.7 Domestic Water Pump**

One set comprising of two nos. domestic water pump shall be supplied, installed, tested and commissioned by the contractor. Each pump shall have a delivery of 2.5 m<sup>3</sup>/hr at a manometric head of 20 metres.

Pump set shall consist of two pumps connected in parallel, pre-piped, pre-wired complete with control panel, strainer, stop valves at inlet and outlet and non-return valves at outlets and ready for installation.

- Pump to be standard catalogue item from renowned manufacturer and made to European Standards.
- Pumps shall have high reliability and quiet running. All critical parts such as casing, impeller and shaft shall be stainless steel.
- The unit shall be self priming and priming maintained after pump shut down.
- Pressure regulating valve shall be provided at pump outlet to control line pressure

- Pump motor to be fully enclosed, fan cooled, rated IP 54 complete with overload/thermal protection and automatic reset.
- Control panel with indicator lights for all modes including normal operation, standby, failure etc.
- Pump controller shall ensure automatic use of one pump if the other is out of order and also even use of both pumps.
- Pump assembly and pressure vessel to be properly mounted/anchored as per manufacturer's recommendations.
- Dry running shall be prevented by means of float switch installed in the water tank.
- The pumping system shall include a pressure vessel of at least 50 L complete with quarter turn isolating valve and properly anchored as per manufacturer's instruction.

### **3.0 Hot water system**

#### **3.1 Hot water draw-off points**

Pressurized hot water shall be supplied to the shower and sink located at ground floor level and the two showers and two wash hand basins located at first floor level.

#### **3.2 Solar Water Heater**

Hot water shall be produced by two evacuated tube type solar water heaters each of at least 300 litre capacity installed on the roof of the building.

The solar water heater and components will conform with MS EN 12976-1:2006 or any other equivalent standard approved by the Mauritius Standards Bureau.

The solar water heater shall be evacuated tube pressurized type. The storage cylinder tank shall be at least of 300 L and shall be manufactured with stainless steel grade 316 and capable of withstanding continuous temperatures at 99°C. The outer casing of the tank shall also be SS 316. Temperature pressure relief valve and air release valve to be preferably inbuilt within the hot water storage tank. Supporting frames and brackets shall be of stainless steel materials and anchors, bolts, nuts, washers, etc to be stainless steel A4-316.

The solar water heater shall be high quality product with at least 7 year warranty period.



### **3.2.1 Hot Water Booster**

The hot water storage tanks shall be equipped with adjustable temperature electric booster to cater for insufficient insulation levels and any drop of water temperature due to prolonged continuous usage. The booster cut off temperature shall be set at 60°C and cut in at 50°C.

Dedicated 230 V 50 Hz power supply shall be provided to each solar heater booster elements and shall be equipped with heavy duty (32A) on/off main electrical isolating switch with neon indicator, appropriate rated Miniature Circuit Breaker (MCB) with associated 30 mA sensitivity Residual Current Circuit Breaker (RCCB) which shall provide protection against overloads, short circuits and earth leakages.

Electrical installation shall conform to BS 7671 or relevant recognized international standards. Approval of the ESD Engineer shall be obtained prior to execution of the installation works.

### **3.3 Solar Water Heater Installation**

The solar water heaters shall be oriented so that all the evacuated collector tubes face towards the North for maximum efficiency. They shall be properly located to minimize shading. The supporting frames/stands shall be securely fixed onto appropriate sized concrete slabs and the whole installation should resist cyclonic wind speeds of up to 280 km/hr.

### **3.4 Pipework Fittings**

The pipework shall comprise of appropriate nos. unions and isolating valves suitably located to allow easy isolation and removal/replacement of the solar water heater assembly without disrupting the effective operation of the water supply system. Moreover, necessary tap connectors and any other additional fittings required shall be fitted in the pipework to enable removal and renewal of valves during maintenance. All fittings used shall be suitable for hot water applications.

#### **3.4.1 Hot Water Valves**

All isolating valves shall be quarter turn type, manufactured for hot water application and of solar type.

Non return valve shall be suitable for hot water with operating temperature of at least 105°C, bronze/brass type, fitted stainless steel spring loaded brass/bronze disc and designed to work effectively in vertical or horizontal orientation as appropriate.

### ***3.4.2 Prevention of Excessive Temperatures***

The outlets from the hot water storage vessels shall be fitted with a device, such as an inline hot water supply thermostatic mixing valve (tempering valve) to ensure that the temperature supplied to the domestic hot water distribution system can be adjusted and does not exceed 45°C. The Thermostatic Mixing Valves shall comply with BS EN 1111 in accordance with EN 15092 and provide failsafe function compliant to TMV 3

### ***3.5 Hot Water Pipework***

Hot water pipework shall be cPVC PN 25 (HTA-Girpi) in compliance with EN ISO15877-1. All fittings used shall also be PVC-C and conform to this same standard. Other materials than cPCV used for the manufacture of fittings shall conform to EN ISO 15877-3. Welding to be effected as per manufacturer's instruction and recommended glue shall be utilized.

The pipes and fittings shall be indelibly marked in order to read their respective compliance, temperatures and pressures.

#### ***3.5.1 Thermal Insulation***

All pipework and fittings shall be efficiently insulated to prevent heat loss.

Insulation shall be in accordance with BS 5970 and BS 5422. Insulation material utilized shall be CFC, HCFC and asbestos free and be fire resistant satisfying requirements of BS 476 Part 1. Insulation thickness shall be 19-25 mm and material of thermal conductivity not greater than 0.039 W/mk.

The method of installing the insulation shall conform to the manufacture's recommendations. Pipework surfaces shall be cleaned and free of dust prior to installation. The insulation shall be finished in a clean manner at all insulated obstructions in the pipework allowing for expansion, contraction, easy access for removal and replacement of valves without disturbing the surrounding insulation.

External exposed pipework shall be protected by means of aluminium cladding over insulation with 25 mm overlap. The cladding shall be neatly finished and sealed with expansive foam and appropriate sealer..

## **4.0 Waste and Sewer Pipes**

### **4.1 Pipework**

All exposed waste and sewage pipe shall be of uPVC non pressure type, rated to withstand at least 6 bars and shall be in compliance with relevant British Standard (BS 45140), ISO 150 R 161 and manufactured to MS 150 4422-2.

Pipes cast in slab shall be of PVC PN10/SN8.

Pipework and fitting to be jointed shall be properly cleaned with PVC cleaner prior to be solvent welded with recommended glue. All joints are to be tested for leaks and a certificate to that effect have to be submitted.

Underground sewer pipes shall be push fit type with rubber ringed joints rated SN 8.

Pipework shall have a gradient of at least 1:100 but not exceeding 1:80.

Pipe support intervals shall be according to manufacturer's specification.

PVC or stainless steel bottle traps shall be used at discharge from wash hand basins and sinks.

Appropriate type PVC shower traps and PVC floor traps with square top shall be provided as required.

All bends on sewer and waste pipes shall be large radius smooth bends.

Waste and soil pipes shall be extended up to or beyond roof level and fitted with vent cowls to facilitate drainage of the system and ensure trap stability.

In case the vent cowls cannot be extended beyond roof level, they shall be suitably located and fitted with air admittance valves so that foul odour emanating there from do not propagate into the building through opened windows.

Adequate rodding eyes shall be provided along the pipelines at changes of direction and wherever required as per good design practice. Elbows fitted with rodding cap shall be fitted as required at connection to each WC pan adaptor and exit of wash hand basins.

#### **4.2 Grease Trap**

Grease trap of capacity 200 L shall be provided at the outlet from kitchen sink .

#### **4.3 Gully Traps**

Waste pipe outlets from showers and wash hand basins shall terminate into P-type gully traps with precast cover before final discharge into manholes.

#### **4.4 Floor Drains**

Shower drains and floor drains shall be of horizontal type with concealed pipe run in flooring. Shower drains should not be interconnected. Each shower drain outlet should terminate to the stack or gully trap.

#### **4.4 Septic Tanks and Leaching Field**

All domestic wastewater shall be disposed via septic tank and effluent filter tank followed by leaching field as shown in the tender drawings.

The septic tank shall have a minimum volume of 3 m<sup>3</sup> and shall be watertight and accessible at all time for inspection and maintenance.

The septic tank shall be located at least 2 m from any building, structure or site boundary.

The leaching field shall have a minimum plan surface area of 30 m<sup>2</sup> and shall be located at least 1 m from any building, structure or site boundary.

The minimum depth of the leaching field shall be 600 mm and the minimum distance from the formation level of the leaching field to the maximum level of water table is to be 1.2 m.

On-site disposal shall be located at least 30 m from the High Water Mark.

The sewage treatment and disposal system shall be as per Design Guidance on Plot Sewage Disposal of the Ministry of Housing and Lands and all installations must be approved by the Wastewater Management Authority (WMA). The Contractor shall submit all required drawings to the WMA as necessary to obtain approval and clearances prior to execution of works.

## **5.0 Fire Fighting System**

### **5.1 Fire extinguishers**

One unit 4 kg dry powder portable fire extinguisher shall be installed for every 100 square metre on each floor of the building and one unit 2 Kg portable carbon dioxide fire extinguisher for the kitchen.

The portable fire extinguishers shall conform with BS EN3, BS5423 and BS 5306 – Part 8 (2006).

The fire extinguishers shall be mounted in such a way so as the position of the carrying handle shall be located at around 1 metre from floor level.

All the fire extinguishers shall be serviced at the time of practical completion or prior to handing over and delivered with recent valid Test Certificates.

### **5.1 Siting of Fire Extinguishers**

Extinguishers should be wall mounted along the line of fire escape routes and located at similar positions across similar floors, so that they can be easily accessed and operated without undue delay.

All points within a building should be within 30 metres from an extinguisher so that it shall not be necessary to travel more than 30 metres from the site of fire to reach an extinguisher. Photo luminescent rigid PVC fire extinguisher identification signs/labels on perspex background to BS 5499 shall be placed as required.

## **6.0 Testing and Commissioning**

The cold water, hot water, waste/sewage and firefighting systems shall be properly commissioned and tested by the contractor. Tests shall be carried out in accordance with agreed and recognized standards such as those produced by BS EN or CIBSE.

Water supply pipes shall be pressure tested to 8 bars and held for at least 8 hours to test for leaks.

Waste and sewer pipe works shall be tested for leaks and air tightness.

The outflow of all cold and hot water draw off points shall be demonstrated with full bore delivery from taps.

All tests will be witnessed by Mechanical Engineer. Upon successful completion of the commissioning and testing exercises, the contractor shall:

- (i) Demonstrate to the client the proper and correct operation of all individual mechanical installations including the pumps, drain valve, solar water heater, electric booster etc.
- (ii) Submit to the Mechanical Engineer the certificates of testing and three copies of operation and maintenance manuals, shop drawings and "as made drawings". The manual shall be of loose leaf type A4 size having stiff plastic covers with sub-divisions for each section and a detailed index. The works shall not be considered as complete unless the as-made drawings as well as the manuals are submitted.

## **7.0 Defects Liability Period**

The defects liability period shall be of 12 months duration. The appointed Contractor shall carry out all necessary maintenance, servicing and repairs during this period free of cost. Any defects or failure due to materials or bad workmanship appearing during this period shall be made good by the Contractor at his own cost.

## **8.0 Pressure Tests**

- 8.1 The whole pipework shall be pressure tested in accordance with BS 6880-3 and BS 6700 and a certificate to that effect shall be submitted to the Engineer.
- 8.2 The pressure tests shall be carried out at every stage and finally on the whole of each completed circuit or system.
- 8.3 The pressure tests shall be carried out with all parts and fittings not designed to withstand the test pressure removed or blanked off and the pipeline suitably anchored to withstand the test pressure.
- 8.4 The pressure tests shall be undertaken before pipework is concealed by structures, covers, partitions, ceilings, insulations, backfilling over joints, final painting, etc.
- 8.5 The Contractor shall inform the Mechanical Engineer or his representative prior to effecting the tests and agree on the date and time to enable the latter to be present in order to witness the tests.
- 8.6 All tests shall be witnessed and tests certificates signed when the test is satisfactorily completed.

## **9.0 General Requirements**

- 9.1 All pipes passing through building elements, (walls, floors, slabs, partitions, etc.) to be enclosed concentrically within purpose made sleeves, to allow removal and expansion or contraction of the pipes.
- 9.2 All pipes shall be properly supported as per standard guide.
- 9.3 No part of pipework, sleeves or ducting shall be used as support system for any type installation .
- 9.4 Pipework ends shall be cut square, reamed, chamfered, free from burrs and cleaned with PVC cleaner prior to solvent weld with appropriate glue.
- 9.5 Pipework, valves, drains, air vents, demountable joints, supports, etc., to be arranged for convenient routine maintenance and renewals
- 9.6 All runs and at items of equipment to be provided with a regularly spaced pattern of demountable joints in the form of unions, flanges, etc., to facilitate disconnection. Isolating valves, non return valves, etc., to be provided with tap connectors to enable easy renewal.
- 9.7 Pipework shall be properly and solidly supported along their whole lengths at intervals as specified by the manufacturer. Appropriate PVC clamps, galvanized saddles, galvanized hangers with tubular clamps, etc. shall be used for that purpose. All fasteners, screws, bolts, nuts, washers etc., shall be corrosion proof (A4/316).
- 9.8 Exposed pipe runs shall run in a neat manner and installed plumb, straight, symmetrical and at right angles to or parallel with other pipe or service runs and building structure, subject to gradients for draining or venting. All pipe work to be colour coded and labelled in accordance with good industry practice.
- 9.9 Pipework to be installed with gradients to allow drainage and/or air release, and to the slopes where necessary.
- 9.10 All valves, vents and accessories must be fitted in such a manner that they are accessible for operation and maintenance. Valve operating handles must be easily accessible and operation must not be impeded by structure or other services.

9.11 No joints of fittings to be allowed in concealed and inaccessible locations.

9.12 All equipment, materials and fittings shall be new and according to specifications.



## EARTHING

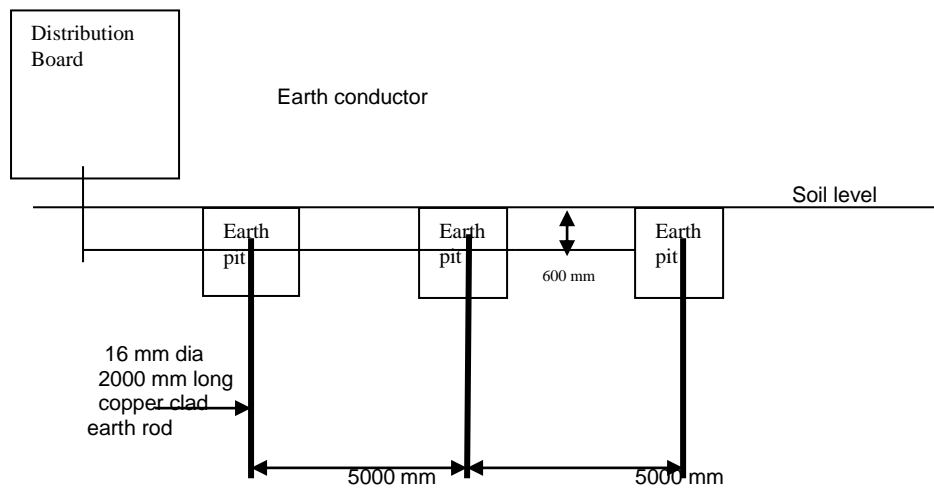

**Note:** The No. of earth rods shown is indicative only. These shall be increased until the desired Earth Resistance is obtained.

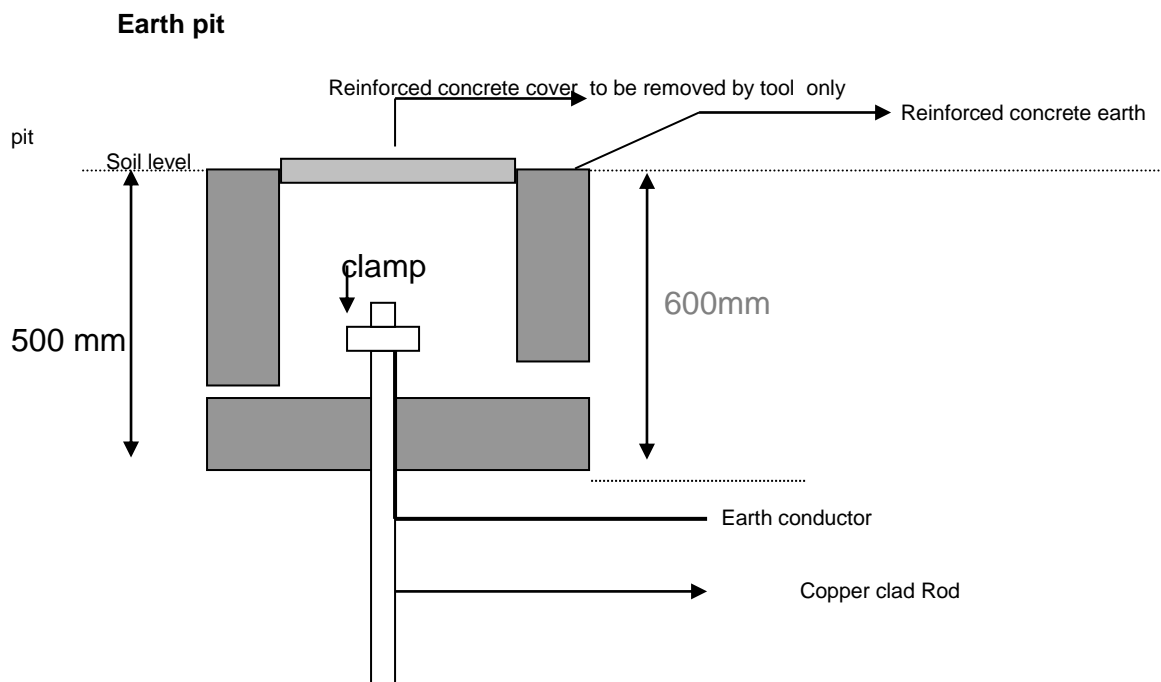

### Specifications for trenches for laying of underground cables

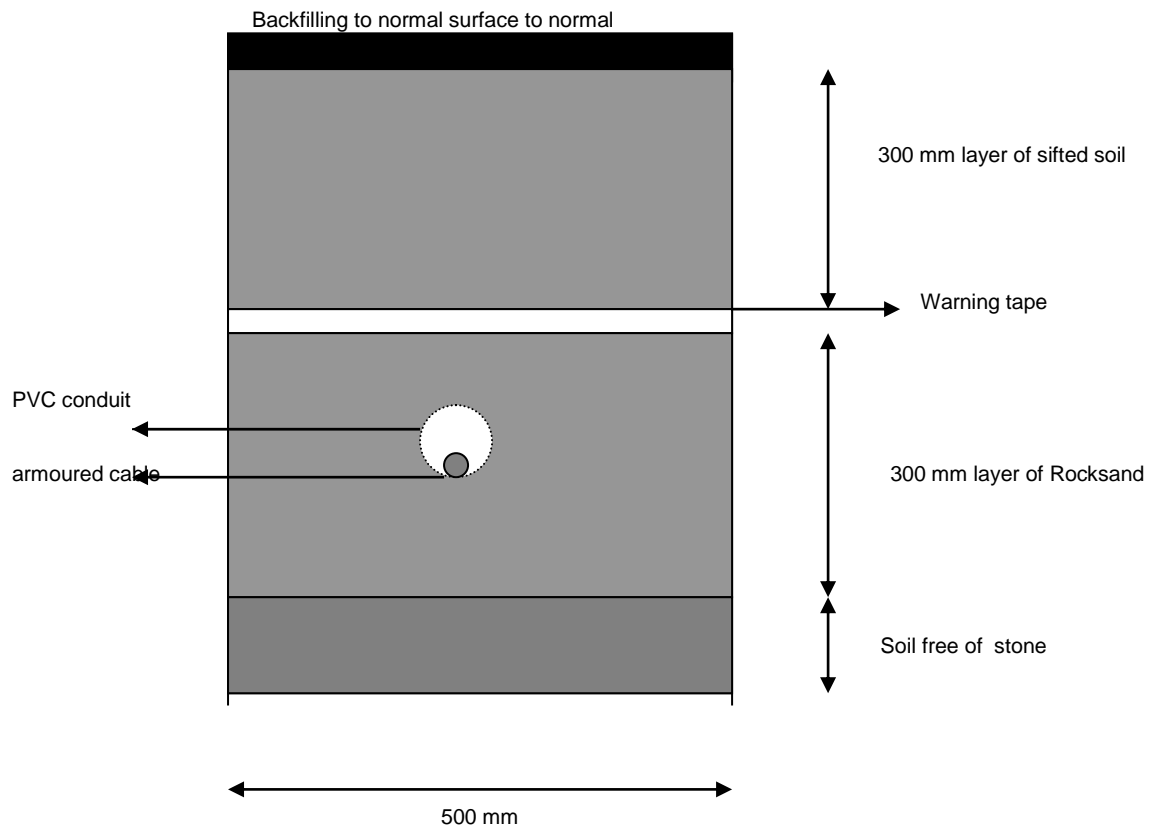

Notes: 1 *Warning tape shall be of plastic type yellow colour 0.5 mm thick 200 mm wide clearly labelled*

**“ DANGER ELECTRICITY ”** over each of 0.5 m

2. *PVC conduit shall be of yellow coloured pressure type.*
3. *Reinstatement work shall be carried after the installation of underground conduit and cable.*
4. *It shall contain more than one PVC conduit in the trenches if needed and shown in site layout.*

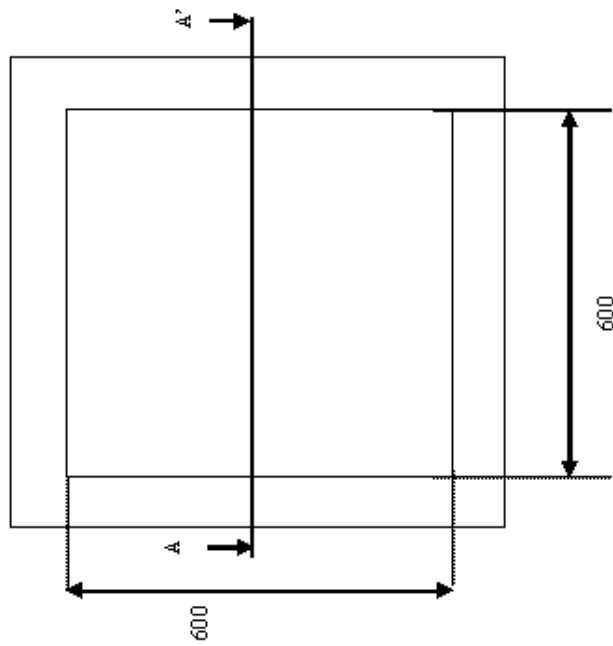
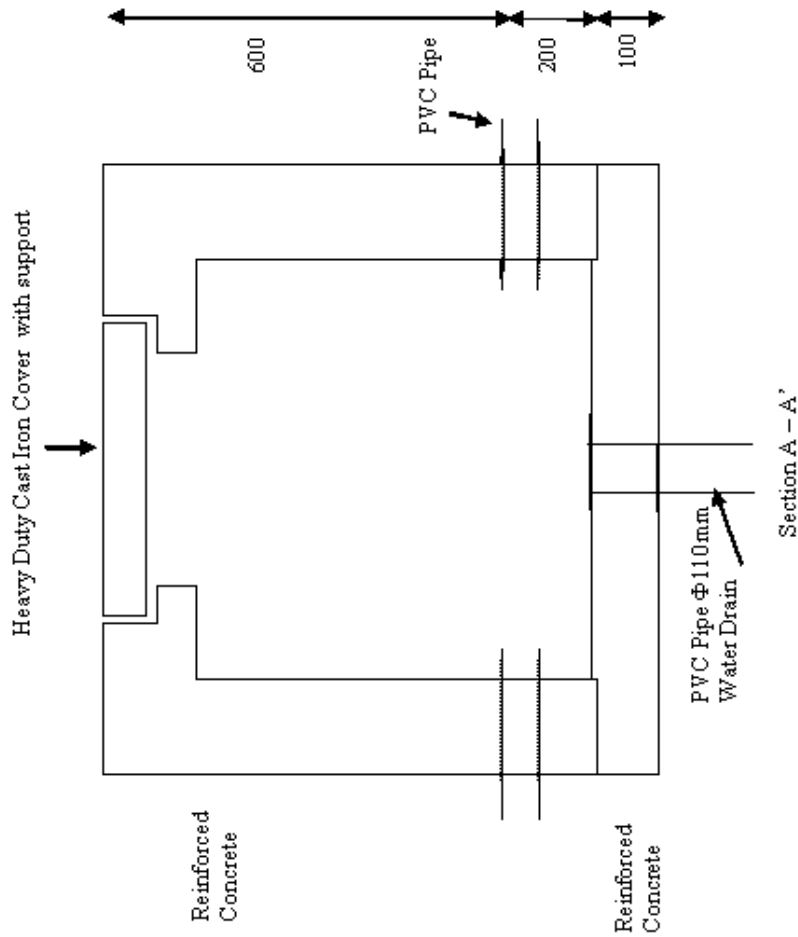

Notes

1. All dimensions are in millimetres
2. Walls of manholes to be plastered
3. Heavy Duty Cast Iron Cover to be 400x400mm
4. Manhole to be made of reinforced concrete

<b>Energy Services Division</b>
Electrical Manhole

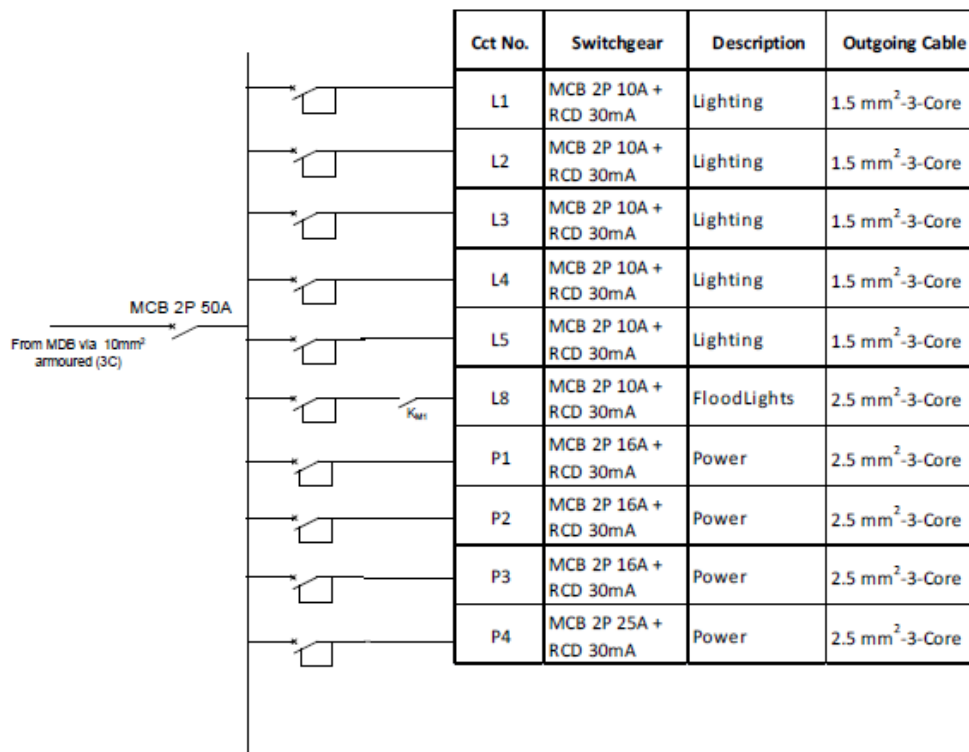

Figure 2. SDB-E

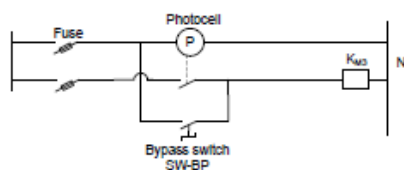

Figure2. Wiring diagram of photocell switch c/w contactor and selector switch

Project: New Fisheries Post at Case Noyale		Title: Schematic Layout of SDB-E	
Energy Services Division	Drawn by: N.S	Checked by: S.B	Date: February 2016
			Revision

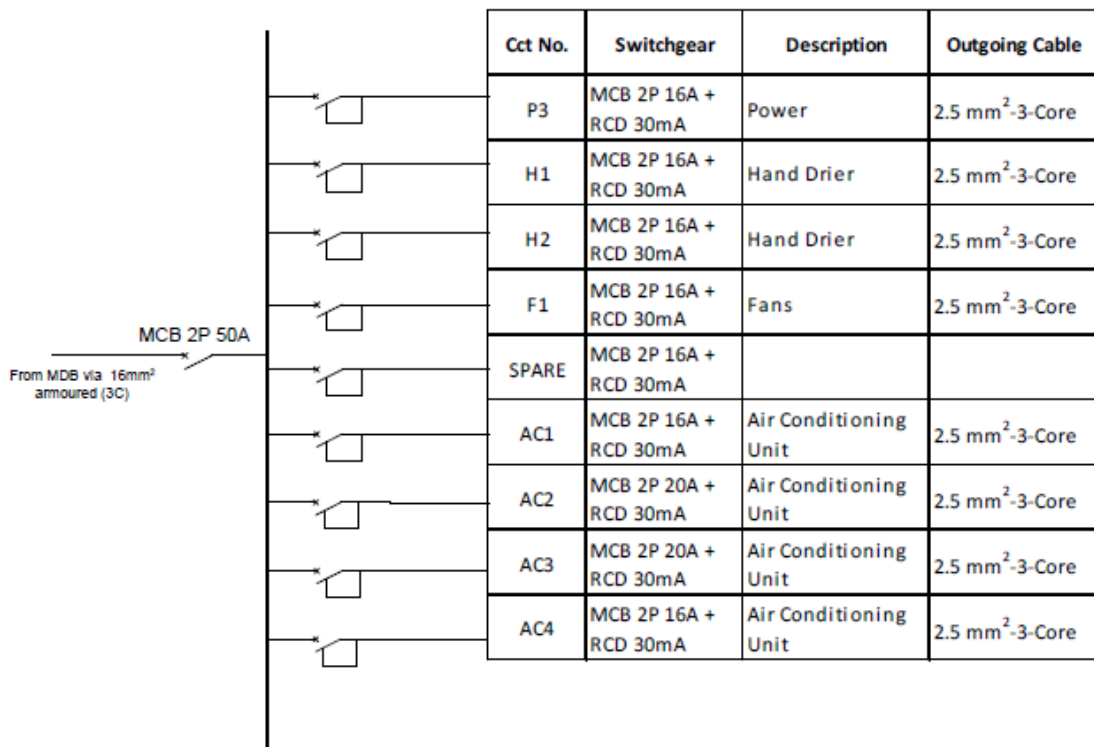

Figure 3. SDB-NE

Project: New Fisheries Post at Case Noyale			Title: Schematic Layout of SDB-NE	
Energy Services Division	Drawn by: N.S	Checked by: S.B	Date: January 2016	Revision

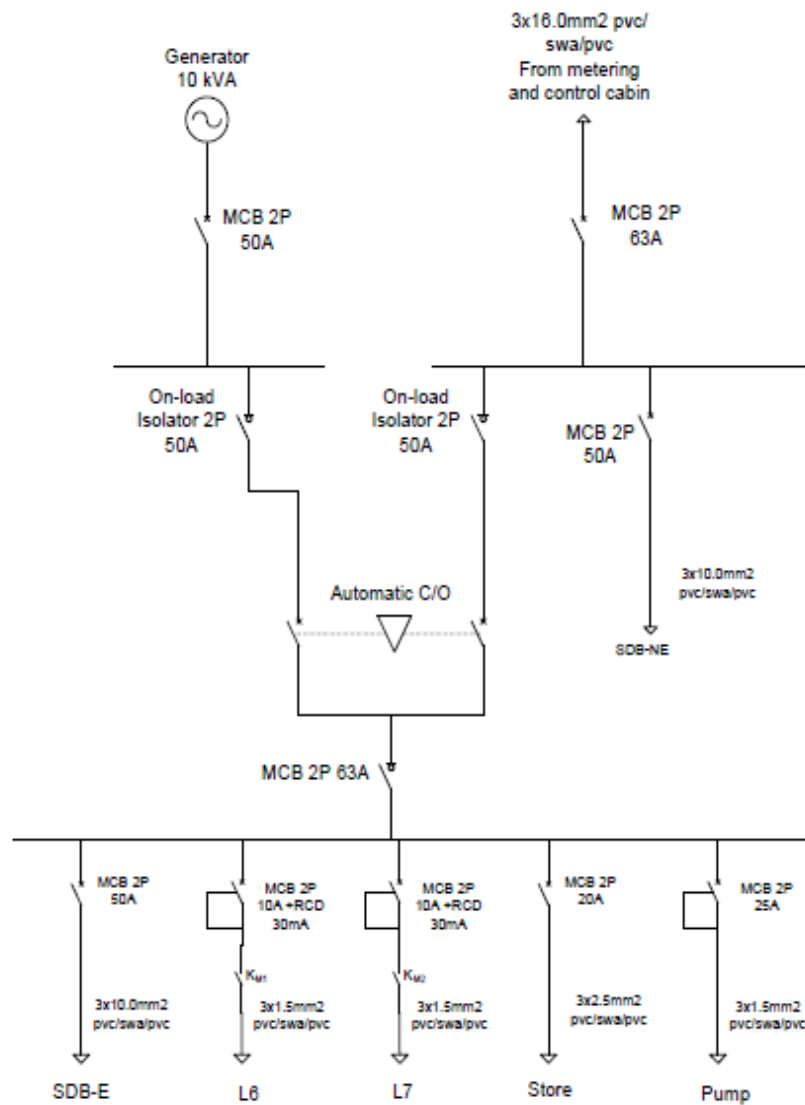

Figure 1. Main Distribution Board

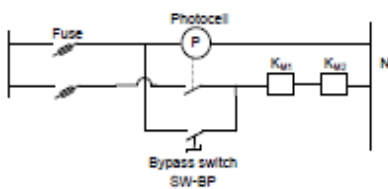

Figure2. Wiring diagram of photocell c/w contactor and selector switch

Project: New Fisheries Post at Case Noyale		Title: Schematic Layout of Main Distribution Board		
Energy Services Division	Drawn by: N.S	Checked by: S.B	Date: February 2016	Revision

## **Drawings**

**LIST OF DRAWINGS AS PER DRAWING NO: AG71/09**

**(SET OF DRAWING AVAILABLE FROM PROCUREMENT SECTION)**

## **ACTIVITY SCHEDULE**

### **GUIDANCE NOTES ON PRICING OF ACTIVITY SCHEDULE**

This is a lump sum tender and shall be based strictly on the information provided in the drawings, specifications, scope of works and other conditions laid in the bid document and not according to this Activity Schedule.

1. The prices given in the Activity Schedule may be used if judged appropriate for the preparation of interim valuations.
2. Prices in the Activity Schedule shall not be used for adjusting the lump sum tender price for extra works or omissions.
3. Any inconsistencies detected in the prices shall be resolved by the Project Manager.
4. The bidder is responsible for ensuring that works are included in his bid price, whether or not an item is given.
5. In the case of the bidder leaving unpriced any items, he will be deemed to have considered that the prices of the remaining items are sufficient to enable him to perform the services and obligations described in the items not priced without extra charge.







ITEM NO	DESCRIPTION	UNIT	QTY	RATE	AMOUNT
<b>C.2</b>	<b>UPPER FLOORS</b>				
<b>C.2.1</b>	<b>SUSPENDED SLABS</b>				
	Reinforced concrete slabs including continuous access floors balconies suspended floors, etc.				
C.2.1.1	First Floor Slab	Sum			
<b>C.3</b>	<b>ROOF STRUCTURE</b>				
C.4.1	Roof Reinforced concrete slab including parapet walls, cornices, upstands and gutters	Sum			
<b>C.4</b>	<b>ROOF COVERINGS</b>				
C.4.1	All works to include roof screeds and finishings. Screed laid to slope comprising of an approved waterproofing compound.	Sum			
C.4.2	Waterproofing membrane as per specifications and to Architect and Engineer's satisfaction and including any necessary flashings	Sum			
<b>C.5</b>	<b>STAIRCASES</b>				
	Staircase including landings, handrail, non-skid homogenous nosing tiles, rendering, painting, etc.	Sum			
	<b>TOTAL CARRIED TO COLLECTION</b>				



ITEM NO	DESCRIPTION	UNIT	QTY	RATE	AMOUNT
<b>C.8</b>	<b>WINDOWS AND EXTERNAL DOORS</b>				
<b>C.8.1</b>	<b>ALUMINIUM OPENINGS</b>				
	Supply and fix aluminium openings within rendered/ concrete surrounds complete with ironmongery, burglar bars, fixing accessories and glazing, and painting all as per Architect schedule of openings and specification.				
	<b>GROUND FLOOR AND FIRST FLOOR</b>				
C.8.1.1	Windows	Sum			
C.8.1.2	Burglar Bars to Windows	Sum			
C.8.1.3	Doors	Sum			
C.8.1.4	Collapsible grills doors	Sum			
C.8.1.5	Duct Doors	Sum			
<b>C.9</b>	<b>INTERNAL WALLS AND PARTITIONS</b>				
	All works to include internal vertical divisions within the buildings and including screens, borrowed lights, moveable space ,dividing partitions, sliding/folding partitions, glazing including all fixtures and fittings to Architect's approval.				
	<b>GROUND FLOOR</b>				
C.9.1	Hollow concrete blocks	Sum			
	<b>FIRST FLOOR</b>				
C.9.2	Hollow concrete blocks	Sum			
	<b>TOTAL CARRIED TO COLLECTION</b>				

ITEM NO	DESCRIPTION	UNIT	QTY	RATE	AMOUNT
<b>C.10</b>	<b>DOORS</b>				
	Work including frames, linings, locks, door closers, trims ironmongeries, glazing, finishes, etc. Concrete works to include all mouldings, lintels, thresholds and work to reveals of openings.				
C.10.1	Timber flush doors at Ground Floor	Sum			
C.10.2	Timber flush doors at First Floor	Sum			
	<b>FINISHES</b>				
<b>C.11</b>	<b>WALL FINISHES</b>				
	Notwithstanding the 'Standard Form Of Cost Analysis' this item shall include external Wall Finishes.				
	Work to include all Finishes applied to walls both internally and externally.				
<b>C.11.1</b>	<b>GROUND FLOOR</b>				
	Rendering				
C.11.1.1	<i>Internally</i>	Sum			
C.11.1.2	<i>Externally</i>	Sum			
C.11.2	Painting				
C.11.2.1	<i>Internally</i>	Sum			
C.11.2.2	<i>Externally</i>	Sum			
C.11.2.3	Ceramic wall tiles	Sum			
<b>C.11.3</b>	<b>FIRST FLOOR</b>				
	Rendering				
C.11.3.1	<i>Internally</i>	Sum			
C.11.3.2	<i>Externally</i>	Sum			
	Painting				
C.11.4.1	<i>Internally</i>	Sum			
C.11.4.2	<i>Externally</i>	Sum			
C.11.4.3	Ceramic wall tiles	Sum			
	<b>TOTAL CARRIED TO COLLECTION</b>				

ITEM NO	DESCRIPTION	UNIT	QTY	RATE	AMOUNT
<b>C.12</b>	<b>FLOOR FINISHES</b>				
	All works to include screeds, skirtings and finishes to floor surfaces.				
	<b>GROUND FLOOR</b>				
C.12.1	Homogeneous non-skid ceramic tiles	Sum			
C.12.2	Coloured Cement screed	Sum			
C.12.3	Tile skirting	Sum			
C.12.4	Painted skirting	Sum			
	<b>FIRST FLOOR</b>				
C.12.5	Homogeneous non-skid ceramic tiles	Sum			
C.12.6	Coloured Cement screed	Sum			
c.12.7	Antistatic non-asbestos vinyl flooring	Sum			
C.12.8	Tile skirting	Sum			
C.12.9	Timber skirting	Sum			
C.12.10	Painted skirting	Sum			
<b>C.13</b>	<b>CEILING FINISHES</b>				
	All works to include finishes to surfaces of soffits including sides and soffits of beams and construction and suspended ceilings.				
	<b>GROUND FLOOR</b>				
C.13.1	Plastering	Sum			
C.13.2	Painting	Sum			
	<b>FIRST FLOOR</b>				
C.13.3	Plastering	Sum			
C.13.4	Painting	Sum			
	<b>TOTAL CARRIED TO COLLECTION</b>				

ITEM NO	DESCRIPTION	UNIT	QTY	RATE	AMOUNT
<b>C.14</b>	<b>SUNDRIES</b>				
C.14.1	Timber balustrade and handrail to staircases	Sum			
C.14.2	Stainless steel balustrade at first floor	Sum			
C.14.3	Timber canopy with bird spikes	Sum			
C.14.4	Timber pergola with polycarbonate sheeting at ground floor	Sum			
C.14.5	Timber pergola with polycarbonate sheeting at covered entrance at first floor	Sum			
<b>D</b>	<b>INTERNAL SERVICES INSTALLATIONS</b>				
	<b>DISPOSAL INSTALLATIONS</b>				
<b>D.1</b>	<b>DRAINAGE</b>				
	Works to include all soil, anti-syphonage and ventilation pipes, rainwater downpipes, floor channels, gratings and Drains.				
D.1.1	Soil pipes	Sum			
D.1.2	Ventilation pipes	Sum			
D.1.3	Rainwater pipes	Sum			
D.1.4	Floor channels and gratings	Sum			
<b>D.2</b>	<b>WATER INSTALLATIONS</b>				
D.2.1	Allow for all internal and external plumbing works including connection to water mains, water tanks, etc.	Sum			
	<b>Water tanks</b>				
D.2.2	Platform for water tank and solar water heater at roof level	Sum			
	<b>TOTAL CARRIED TO COLLECTION</b>				



ITEM NO	DESCRIPTION	UNIT	QTY	RATE	AMOUNT
<b>D.3</b>	<b>SANITARY APPLIANCES</b>				
	All sanitary appliances such as bath, basins, sinks, etc, WC's, urinals, toiletroll holders, towel rails, traps, waste fittings,overflows and taps.				
D.3.1	Wash hand basins	Sum			
D.3.2	European WC	Sum			
D.3.3	Stainless steel sink	Sum			
D.3.4	External basin	Sum			
D.3.5	Toilet Soap Holder	Sum			
D.3.6	Toilet roll holders	Sum			
D.3.7	Towel rails	Sum			
D.3.8	Mirrors	Sum			
D.3.9	Handspray	Sum			
D.3.10	Shower kit	Sum			
D.3.11	Floor trap	Sum			
D.3.12	Handspray	Sum			
D.3.13	Sanitary toilet disposal	Sum			
<b>D.4</b>	<b>EXTERNAL WATER INSTALLATIONS</b>				
	<b>Builder's work in connection with services installation</b>				
D.4.1	Allow works connection with plumbing Installations	Sum			
D.4.2	Sanitary appliances	Sum			
D.4.3	Disposal installations	Sum			
D.4.4	Water installations	Sum			
	<b>TOTAL CARRIED TO COLLECTION</b>				

ITEM NO	DESCRIPTION	UNIT	QTY	RATE	AMOUNT
<b>D.5</b>	<b>EXTERNAL SERVICES INSTALLATIONS</b>				
D.5.1	External services installations , soil and waste pipes including works and connection to manholes, existing sewer main/septic tank, absorption pits, leaching fields, grease traps, gully traps, etc.	Sum			
D.5.2	Manholes	Sum			
D.5.3	Leaching field	Sum			
D.5.4	Catch pits	Sum			
D.5.5	Gully traps	Sum			
D.5.6	Soakaways	Sum			
D.5.7	Septic tank	Sum			
D.5.8	Effluent Filter tank	Sum			
D.5.9	Distribution Manhole	Sum			
D.5.10	Inspection Manhole	Sum			
D.5.11	MT Manhole	Sum			
D.5.12	Electrical Manhole	Sum			
<b>E</b>	<b>EXTERNAL WORKS</b>				
	<b>Site Works</b>				
	<b>Site Preparation</b>				
E.1	All works to include site clearance, site levelling, and any necessary earthworks cut and fill, felling of trees and grubbing up roots, and all carting away as necessary	Sum			
E.2	Flag Poles	Sum			
E.3	Boundary Walls	Sum			
E.4	Tarmac	Sum			
	<b>TOTAL CARRIED TO COLLECTION</b>				



ITEM NO.	DESCRIPTION	UNIT	AMOUNT (Rs)
1	Supply, install, test and commissioning of the following distribution boards with hinge lockable door and all components (MCCB's, MCBs, RCBOs, ELCB's, earth bars, neutral bars, and other accessories) according to the respective electrical schematic and specifications		
1.1	MDB	Lot	
1.2	SDB-E	Lot	
1.3	SDB-NE	Lot	
2	Standby Generator set of 10 kVA c/w soundproof canopy, engine fuel tank, first fill of tanks, antivibration pads, control panel, automatic changeover panel, etc as per specifications	Lot	
3	Supply, install, test and commissioning of all cabling works	Lot	
4	Supply, install, test and commissioning of all conduit works (PVC pressure pipe, PVC conduit, flameproof conduit etc...)	Lot	
5	Supply, install, test and commissioning of all luminaires	Lot	
6	Supply, install, test and commissioning of all sockets	Lot	
7	Supply, install, test and commissioning of all switches	Lot	
8	Supply, install, test and commissioning of extractor fans	Lot	
9	Supply, install, test and commissioning of ventilating fans	Lot	
10	Supply, install, test and commissioning of earthing system	Lot	
11	Supply, install, test and commissioning of all air conditioning units	Lot	
12	Supply, install, test and commissioning of hand driers	Lot	
	<b>TOTAL CARRIED TO COLLECTION</b>		



ITEM	DESCRIPTION	UNIT	Qty	RATE (Rs)	AMOUNT (Rs)
<b>1.0</b>	<b>Cold Water System</b>				
<b>1.1</b>	<b><i>Water storage tanks and accessories</i></b>				
	Supply, install, test and commission				
A	Fibre glass/polyethylene water storage tank suitable for potable water having a capacity of 4500 L complete with 3/4" heavy duty ball cock and installed on reinforced concrete base at ground level.	No.	1		
	Quarter turn valves				
	(i) 3/4" at inlet	No.	1		
	(ii) 1 1/2" at outlet	No.	1		
	(iii) 1 1/2" for draining of tank.	No.	1		
B	Fibre glass/polyethylene water storage tanks suitable for potable water each having a capacity of 1000 lts and installed on roof	No.	2		
	Quarter turn valves				
	(i) 1/2 " at inlet	No.	2		
	(ii) 1 1/4 " at outlets	No.	2		
	(iii) 1 1/4" for draining of tank	No.	2		
<b>1.2</b>	<b><i>Domestic water pump set and accessories</i></b>				
	Supply, install, test and commission				
A	Cold water booster pump set comprising of two pumps each of capacity 2.5 m <sup>3</sup> /hr at 20 metre head, factory assembled complete with 50 L pressure vessel and vibration isolation mounting. Electronic panel, 2 ph, 240 V, 50 Hz c/w 4 stop valves and 2 nos non-return valves, pressure switches, pressure relief valves, etc.	Set	1		
<b>TOTAL CARRIED TO COLLECTION</b>					

ITEM	DESCRIPTION	UNIT	Qty	RATE (Rs)	AMOUNT (Rs)
B	Float level switch for dry running control of pump set. 250 V, 50 Hz c/w control and power cables.	Set	1		
<b>1.3</b>	<b>Pipework</b>				
	Supply, install, test and commission UPVC PN16 and HDPE PN16 of all required dimensions				
A	CWA mains feed pipe work to storage tank at ground level complete with isolating valve, unions, etc..	Lot	1		
B	Bypass pipework from CWA main to pump outlet complete with non-return valves and isolating valves (for use in case of pump failure, maintenance and insufficient water pressure at ground floor level).	Lot	1		
C	Pipework from CWA bypass to draw off points at first floor level	Lot	1		
D	Gravity feed pipework from roof storage tanks to bypass and draw off points at first floor level	Lot	1		
E	Suction pipework from storage tank to booster pump set	Lot	1		
F	Pressurized water supply to (i) roof water tanks (ii) solar water heaters (iii) thermostatic mixing valves (iii) draw off points at first floor level (iv) draw off points at ground floor level	Lot	1		
G	PEX single run pipework 16/12 sleeved in 32 mm isorange PVC conduit from manifolds to all user points	Lot	1		
H	Pressure testing of above pipe-works before backfilling.	Lot	1		
<b>TOTAL CARRIED TO COLLECTION</b>					

ITEM	DESCRIPTION	UNIT	Qty	RATE (Rs)	AMOUNT (Rs)
<b>1.4</b>	<b><i>Pipework fittings and accessories</i></b>				
	Supply, install, test and commission				
A	UPVC PN16 solvent welded				
	(i) unions of all required dimensions	Lot	1		
	(ii) tees of all required dimensions	Lot	1		
	(iii) elbows of all required dimensions	Lot	1		
	(iv) tee reduce of all required dimensions	Lot	1		
	(v) reduce bushing and sockets of all required dimensions	Lot	1		
	(vi) male and female threaded couplings, nipples, etc. of all required dimensions	Lot	1		
B	Brass fittings, adaptors, nipples etc.	Lot	1		
C	Isolating valves, Non return valves and Tap connectors	Lot	1		
D	Chrome plated angle valves and full bore mini ball valves in brass and nickel plated body	Lot	1		
E	Chrome plated flexible pipes ½" of various appropriate lengths	Lot	1		
F	Pressure regulating valves and Automatic air release valve	Lot	1		
G	Brass manifold, single inlet with multiple outlets complete with miniball valves at outlet.	Lot	1		
H	HDPE transition fittings and adaptors	Lot	1		
I	Clips, saddles, hangers, PVC brackets, etc. complete with stainless steel screws and stainless steel threaded rods and other fixation accessories all of appropriate dimensions for complete installation	Lot	1		
J	Supply, install, test and commission any other items not mentioned above but which are required for a complete and fully operational system. <b>Give details below:</b>				
(i)					
(ii)					
<b>TOTAL CARRIED TO COLLECTION</b>					



ITEM	DESCRIPTION	UNIT	Qty	RATE (Rs)	AMOUNT (Rs)
<b>2.0</b>	<b>Hot Water System</b>				
<b>2.1</b>	<b><i>Solar water heater</i></b>				
	Supply, install, test and commission				
A	Evacuated tube pressure type solar water heater of at least 300L hot water storage capacity, fully stainless steel 316 storage tank and supporting frame, all A4 316 stainless steel screws, bolts, nuts, washers, anchors, etc.	Lot	2		
B	Pressure and temperature relief valves, electric booster element, etc.	Lot	2		
C	Electric power supply to booster element complete with switches, breakers etc.	Lot	2		
<b>2.2</b>	<b><i>Hot water pipework and insulation</i></b>				
	Supply, install, test and commission				
A	CPVC PN 16 - HTA pipework of all required dimensions from solar water heater via thermostatic mixing valve to hot water draw off points	Lot	1		
B	Pipework insulation 19–25 mm thick (Armaflex) c/w aluminium cladding.	Lot	1		
C	Armoured flexible pipes for expansion compensation of hot water pipes.	Lot	1		
D	PEX single run pipework 16/12 sleeved in 32 mm isorange PVC conduit from manifolds to all user points	Lot	1		
<b>2.3</b>	<b><i>Pipework fittings and accessories</i></b>				
	Supply, install, test and commission				
A	CPVC PN16 - HTA				
	(i) unions, tees, elbows, reduce tees, bushings and sockets of all required dimensions	Lot	1		
	(ii) male and female threaded couplings, nipples, etc. of all required dimensions	Lot	1		
<b>TOTAL CARRIED TO COLLECTION</b>					

ITEM	DESCRIPTION	UNIT	Qty	RATE (Rs)	AMOUNT (Rs)
B	Brass fittings, adaptors, nipples etc.	Lot	1		
C	Isolating valves for solar water heater	Lot	1		
D	Non return valves designed for hot water with SS spring loaded brass/bronze disc	No.	2		
E	Adjustable type thermostatic mixing valve (3 way)	No.	2		
F	Brass manifold, single inlet with multiple outlets complete with miniball valves at outlet.	Lot	1		
G	Chrome plated angle valves and full bore mini ball valves in brass and nickel plated body	Lot	1		
H	Chrome plated flexible pipes ½" of various appropriate lengths	Lot	1		
I	Clips, saddles, hangers, PVC brackets, etc. complete with and other fixation accessories all of appropriate dimensions for complete installation.	Lot	1		
J	Stainless steel threaded rods and stainless steel screws, nuts, washers etc. of type A4				
K	Supply, install, test and commission any other items not mentioned above but which are required for a complete and fully operational installation system.	Lot	1		
<b>3.1</b>	<b><i>Irrigation Pipework and Accessories</i></b>				
	Supply, install, test and commission				
A	Underground HDPE DN 25/20 PN10 cold water pipework with electrofusion weld joints buried within trenches, c/w all fittings and accessories, marker tape, etc.	Lot	1		
B	Valve box c/w isolating valve	No.	1		
D	Chrome plated brass bib tap fitted with hose union connection	No.	3		
<b>TOTAL CARRIED TO COLLECTION</b>					

ITEM	DESCRIPTION	UNIT	Qty	RATE (Rs)	AMOUNT (Rs)
<b>3.0</b>	<b>Waste and Sewer System</b>				
<b>3.1</b>	<b>Pipework</b>				
	Supply, install, test and commission				
A	UPVC SN8 160mm $\phi$ push fit rubber ring type sewer pipe work to be laid underground	Lot	1		
B	UPVC SN6 110mm $\phi$ sewer pipe work, solvent welded	Lot	1		
C	UPVC SN6 50mm $\phi$ waste pipe work, solvent welded	Lot	1		
D	UPVC SN6 40mm $\phi$ waste pipe work, solvent welded	Lot	1		
E	UPVC ventilation stack	Lot	1		
<b>3.2</b>	<b>Pipework Accessories</b>				
	Supply, install, test and commission				
A	UPVC SN6 110mm $\phi$ elbows, swept tees, single Y-tees, reducers, etc. solvent welded of all required dimensions for complete installation	Lot	1		
B	UPVC SN6 110mm $\phi$ swept tees and single Y-tees with screwed caps solvent welded of all required dimensions for rodding purposes	Lot	1		
C	PVC vent cowls and PVC membrane aerators	Lot	1		
D	PVC bottle traps of 40 mm $\phi$ and 50 mm $\phi$ , Pan Adaptors, etc.	Lot	1		
E	Shower floor traps PVC 100x100 mm x 50 mm outlet	Lot	1		
F	Heavy duty floor drains with stainless steel cover 150mm x 150mm complete with fittings as required for complete installation	Lot	1		
G	110 mm $\phi$ PVC pan adaptors	Lot	1		
H	Grease trap 200L capacity for kitchen	No	1		
I	Stainless steel basket grille sieve of 1mm <sup>2</sup> for grease trap	No	1		
J	Gully traps, P-type traps with precast cover	Lot	1		
<b>TOTAL CARRIED TO COLLECTION</b>					

ITEM	DESCRIPTION	UNIT	Qty	RATE (Rs)	AMOUNT (Rs)
K	Clips, saddles, hangers, PVC brackets, etc. complete with stainless steel screws and stainless steel threaded rods and other fixation accessories all of appropriate dimensions for complete installation	Lot	1		
L	Supply, install, test and commission any other items not mentioned above but which are required for a complete and fully operational system. <b>Give details below:</b>	Lot	1		
(i)					
(ii)					
(iii)					
<b>4.0</b>	<b>Fire Fighting</b>				
	<i>Portable fire extinguishers</i>				
	Supply, install, test and commission				
A	4 Kg bottle type dry powder ABC fire extinguishers	Lot	1		
B	2 Kg carbon dioxide fire extinguisher	No	1		
C	Photo luminescent rigid PVC fire extinguisher signs on Perspex background screwed to background concrete wall to BS 5499	Lot	1		
D	Supply, install, test and commission any other items not mentioned above but which are required for a complete and fully operational fire fighting system. <b>Give details below:</b>	Lot	1		
(i)					
(ii)					
(iii)					
<b>TOTAL CARRIED TO COLLECTION</b>					

ITEM	DESCRIPTION	UNIT	Qty	RATE (Rs)	AMOUNT (Rs)
<b>5.0</b>	<b>Other items</b>				
A	Liaising with CWA for connection of water supply and installation of water meter	Lot	1		
B	Builder's works, civil works and other associated works related to the mechanical installations	Lot	1		
C	Supply 3 sets of as made drawings for all the mechanical installation works, including cold and hot water, waste and sewage, etc.	Lot	1		
D	Supply 3 sets of O & M manuals for the whole system.				
E	Testing and commissioning the whole of the foregoing system in accordance with the rules, regulations and requirements as described in the specifications.	Lot	1		
F	Supply, install, test and commission any other required items/equipment/accessories, not mentioned above but which are necessary for the successful completion of the whole mechanical installations. <b>Give details below:</b>	Lot	1		
(i)					
(ii)					
(iii)					
(iv)					
(v)					
<b>TOTAL CARRIED TO COLLECTION</b>					

## COLLECTION

	Page No	Amount (Rs)
<b><i>Brought forward from page</i></b>	<b>99</b>	
	<b>100</b>	
	<b>101</b>	
	<b>102</b>	
	<b>103</b>	
	<b>104</b>	
	<b>105</b>	
	<b>106</b>	
	<b>107</b>	
	<b>108</b>	
	<b>109</b>	
	<b>110</b>	
	<b>111</b>	
	<b>112</b>	
	<b>113</b>	
	<b>114</b>	
	<b>115</b>	
	<b>116</b>	
	<b>117</b>	
	<b>118</b>	
	<b>119</b>	
<b><i>TOTAL Carried to Main Summary</i></b>		

**MAIN SUMMARY**

	<b>Rs</b>	<b>Cs</b>
1. Amount of Contractor's price to carry out and complete the works as specified in the Instructions to bidders, Bidding data sheet, Preliminaries and General Costs, Drawings, Conditions of Contract and special conditions of contract, Scope of Works and Specifications.		
2. <b>CONTINGENCY SUM</b> Allow the contingency sum of Rupees <b>Five Hundred Thousand</b> to be used at the discretion of the Employer & deducted in whole or part, if not required.	<b>500 000</b>	<b>00</b>
<b>SUB – TOTAL 1</b>		
Lump Sum discount (if any)		
<b>SUB – TOTAL 2</b>		
VAT at 15%		
<b>TOTAL AMOUNT</b>		

**Priced Activity Schedule Authorised By:**

Signature:..... Name:.....

Position:..... Date:.....  
(DD/MM/YY)

Authorised for and on behalf of:

Company:.....

VAT registration No: .....

## Preliminaries and General Costs

### 1. Schedule of Rates

The successful Contractor is requested to fill the SCHEDULE OF RATES to cover all items and work in this contract.

The Schedule must be agreed with the Quantity Surveyor before the Contract is signed and will form part of Contract.

The rates shown on the schedule shall be used for adjusting extras or omissions (NOT APPLICABLE)

### 2. Ordering of Materials fitting an equipment

The selected Contractor shall place orders at the very beginning of the contract for materials, fittings and items of equipment required for this work.

Non-availability of these items will not be considered as an excuse for delay on the works.

### 3. Discrepancies

Should the Contractor at any time discover discrepancies between drawings, description of works or any other documents or in dimensions instructions, he shall immediately refer same to the Employer who shall decide the course to be followed. Failure on the part of the Contractor to comply with this Clause may invalidate any subsequent claim made by him.

### 4. Contractor to visit site

Contractor shall visit the site before tendering and ascertain the nature of the ground and subsoil to be excavated, the contours thereof and acquaint himself with local conditions, site conditions, site restriction, working space available, means of access, limitation and restrictions to access, risk of damage to adjacent properties, roads, etc.

The contractor will have to carry out any other survey that in his opinion is necessary for him to submit a proper proposal. This survey shall also include the services underground or above that may run on site and he shall allow in his offer for their deviation if required.

### 5. Area to be occupied by Contractor

The area of the site which may be occupied by the Contractor for his use as storage or for erection of workshops etc, shall be defined on this site by the Employer.



**6. Access to Site and Temporary Roads**

Means of access to the site shall be agreed with the Employer prior to the commencement of the work and Contractor must allow here for building any temporary access roads, gantries for the transport and lifting of all materials, plants and workmen required for the complete execution of the works, including the provision of temporary culverts, crossing bridges or other means of gaining access to the site. Upon the completion of the works the Contractor shall leave such temporary, access roads, culverts etc. Undisturbed unless ordered otherwise by the Employer. No claims will be entertained for such temporary services left on site or for their removal and restoration on the site to the original condition.

**7. Maintenance of Roads**

The Contractor shall allow for maintaining and keeping public and private roads free from mud debris, etc, arising from the works throughout the duration of the contract.

**8. Plant, Tools, Scaffolding etc...**

The Contractor shall provide all necessary plants, tools scaffolding and vehicles for the efficient and expeditious execution of the works and at or before completion clear same from building and site and make all good.

**9. Setting Out**

The Contractor shall set out the works in accordance with the dimensions and levels shown on the approved drawings and shall be responsible for the correctness of all dimensions and levels so set out by him. He will be required to rectify all errors arising from inaccurate setting out at his own cost and expense. In event of error or discrepancy in the dimensions or levels marked out on the drawings being discovered, such errors or discrepancies shall be reported by the Contractor to the Employer for his immediate consideration.

No work connected with such errors shall be continued by the Contractor until he has received written instructions from the Employer to adjust such discrepancies.

**10. Discharge of Workmen**

The Contractor shall only employ qualified foremen, artisans and labourers on the works. If, in the opinion of the Employer any person employed by the Contractor misconducts himself or is likely to cause or has caused strikes, quarrels or delays, or is incompetent the Contractor, when so directed by the Employer in writing shall at once remove such person from the works site.

**11. Government Ordinance and Regulations**

The Contractor must also make himself acquainted with current ordinance and any Government regulations regarding the movement housing security and control of labour camps, passes for transport etc... and allowance must be made in his Tender for compliance therewith in so far as they are practicable. It is important that the Contractor before tendering shall obtain from the relevant Authority the fullest information regarding all such regulation and/or

restrictions which may affect the organisation of work, supply and control of labour, etc... and allow accordingly in his Tender. No claim for want of knowledge in this connection will be entertained.

**12. Water, Light and Power, telephone**

The Contractor shall provide at his own risk and cost the water, light and power required for use in the work and make them available free of charge to sub-contractor and others.

The Contractor will be required to arrange for the installation of a temporary connection to the main water supply and to provide himself with all necessary temporary water piping and storage tanks as required or directed, remove same and make good disturbed surfaces at completion to the satisfaction of the Employer and pay all charges for meter hire and water consumed until the completion of works.

The Contractor shall provide and maintain a temporary telephone service on site for the full period of the contract at his own costs.

**13. Watching and Lighting**

The Contractor, from commencement of the contract, shall provide all watching lighting and protection of the works, materials and public through fares as may be necessary for the safety of the works, and for the protection of the public and his own employees.

**14. Sheds for Storage of Materials**

The Contractor shall provide and maintain to the satisfaction of the Employer and clear away on completion of the works water tight sheds for the storage and protection of all materials required for the proper execution of the work. He shall also provide storage sheds as may be required by sub contractors nominated sub-contractors and nominated suppliers and remove same when ordered.

**15. Foreman's Office**

The Contractor shall provide a temporary office for the use of the foreman on the site in a position to be agreed by the Employer.

**16. Sanitation for work People**

Adequate sanitary accommodation for his work people etc... shall be arranged and maintained by the Contractor to a standard satisfactory to the Ministry of Health or Health and Sanitation Department of the Local Authority/District Council and/or Labour Inspector.

The Contractor shall provide satisfactory housing for the watchman and water-borne latrine, accommodation for the labour employed on site. Whether by himself or by nominated sub-contractors and/or suppliers and arrange for and pay all charges in connection therewith and allow for removing same

and leaving ground clean and free from pollution to the entire satisfaction of the Employer.

**17. Sign Board**

The sign boards for the display of the General and sub-contractor's names shall be approved size and design with neat and uniform lettering.

**18. Testing of Material**

The Employer shall make such tests of the samples of any materials as he may at his discretion deemed desirable, and the cost of such tests shall be added to the Contract Sum unless the result of such tests causes the Employer to reject any samples or materials as not being in his opinion in accordance with the specification in which case the Contractor shall pay for such tests and the cost thereof shall be recovered therefrom from the Contractor by deduction from the Contract Sum.

**19. Protective and Delivery**

The Contractor shall allow for covering up and protection of work liable to damage, including temporary roofs, gutters, drains etc. If necessary, case up, cover, or in other suitable way protect all finished work liable to injury to the satisfaction of the Employer until completion of the contract. On completion the whole of the works shall be delivered up clean, complete and perfect in every respect to the satisfaction of the Employer

**20. Employer's facilities**

The Contractor is to allow for the costs of facilities on site but not limited to the following:

(i). **Office for Supervisory Staffs**

The Contractor shall provide effect and maintain where directed on the site an approved weather and sunproof temporary office for use of the Supervisory staffs floor size of 6m" x 3m and shall provide the following:

- (a) A long suitable table size 80" X 30"  
(2440 mm X 915 mm)
- (b) 8 Chairs
- (c) 1 pin Board

(ii) **Survey and Testing Equipment**

As may be necessary on site.

**21. Removal of Plant and Rubbish**

The Contractor shall, upon completion of the works, at his own expense remove and clear away all plant, rubbish and unused materials and shall leave the whole of the site in a clean and tidy state to the satisfaction of the Employer. He shall also remove all rubbish and dirt from the site as it accumulates at the discretion of the Employer.

**22. Hoardings**

The Contractor is to provide for all necessary hoardings, as appropriate, along the boundaries allocated to him in order to secure the site.

**23. Restrictions**

Allow for the cost of restrictions including but not limited to the following:

**(a) Limitation of Workmen:**

The Contractor shall keep all persons including those employed by Sub-contractors under control and within the boundaries of the area allocated to him.

**(b) Limitation of construction activity**

The Contractor shall be required to limit the construction activity, Temporary buildings, storage of equipment and materials etc within the boundaries of the area allocated to him.

## **PART 3 – Conditions of Contract and Contract Forms**

## Section VI. General Conditions of Contract

The General Conditions of Contract (GCC) applicable for this procurement is available on the web site of the Procurement Policy Office [ppo.govmu.org](http://ppo.govmu.org) under Ref. No. **W/GCC 10/05-14** dated **May 2014**

The GCC can be used for both admeasurement contracts and lump sum contracts.

## Section VII. Particular Conditions of Contract

These clauses should be read in conjunction with the General Conditions of Contract

<b>A. General</b>	
<b>GCC 1.1 (r)</b>	The Employer is <b>Ministry of Ocean Economy, Marine Resources, Fisheries and Shipping 4<sup>th</sup> Floor, LIC Centre, President John Kennedy Street, Port Louis</b>
<b>GCC 1.1 (v)</b>	The Intended Completion Date for the whole of the Works shall be <b>210 Days</b> from the start date
<b>GCC 1.1 (y)</b>	The Project Manager is <b>Director, Architect Section, Public Infrastructure Division, Phoenix.</b>
<b>GCC 1.1 (aa)</b>	The Site is located at <b>Case Noyale.</b>
<b>GCC 1.1 (dd)</b>	“The Start Date shall be <b>14 days after handing over of site.</b> ”
<b>GCC 1.1 (hh)</b>	<p>The project consist of the construction of the main building, an inflammable store, generator room and site works consisting of parking spaces and wastewater disposal system and other ancillary works as more fully described on drawings and specifications..</p> <p>The main building is a ground and first floor structure in RC concrete and block wall structure, RC roof slab, render and paint finish to wall and ceiling generally, wall tiles finishes internally, floor tiles, openings, electrical works and other ancillary works as more fully described in drawings.</p> <p><u>Site Works</u> The Site Works includes Parking Facilities, Drive Way , Inflammable Store, Generator room, Flag poles, Water Tank, Boundary Wall, Manholes, Septic Tank, Soakaways, Effluent Filter Tank and Leaching Field, and other works as shown on drawings.</p>
<b>GCC 2.2</b>	Sectional Completions are: <b>Not applicable</b>
<b>GCC 2.3(i)</b>	<p>The following documents also form part of the Contract: <b>Performance Security, Preference security, Insurance Policies, Scope of Works, drawings, specifications, Conditions of contract, Particular conditions of contract, Priced activity schedules and addenda.</b></p> <p>The performance security and insurance policies shall be submitted within <b>21 days</b> as from the date of receipt of Letter of Acceptance, for verification</p>

	<b>before the handing over of site.</b>
<b>GCC 3.1</b>	The language of the contract is English  The law that applies to the Contract is the law of Mauritius.
<b>GCC 5.1</b>	The Project manager <b>may</b> delegate any of his duties and responsibilities.
<b>GCC 8.1</b>	Schedule of other contractors: <i>Not applicable</i>
<b>GCC 13.1</b>	<p>Except for the cover mentioned in (d)(i) hereunder, the other insurance covers shall be in the joint names of the Contractor and the Employer and the minimum insurance amounts shall be:</p> <p>(a) for the Works, Plant and Materials: <b><u>(for the full amount of the works including removal of debris, professional fee etc...)</u></b></p> <p>(b) for loss or damage to Equipment: <b><u>(for the replacement value of the equipment that the contractor intends to use on site until the taking over by the Employer.) Evidences to be produced by Contractor.</u></b></p> <p>(c) for loss or damage to property <b>(except the Works, Plant, Materials, and Equipment) in connection with Contract for an amount of Rs5,000,000 (Five Million Rupees) representing the value of the properties that are exposed to the action of the contractor in the execution of the works. It will extend to the property of the Procuring Entity as well). This cover shall be in the joint name of the two parties.</b></p> <p>(d) for personal injury or death:</p> <p>(i) of the Contractor's employees: <i>[The Contractor shall take an adequate insurance cover for its employees for any claim arising in the execution of the works. Evidences to be produced by Contractor].</i></p> <p>(ii) of other people: <i>[This cover shall be for an amount of Rs 10,000,000 (Ten million rupees), for any one occurrence or a series of occurrences arising out of any one event, for Third Party extended to the Employer and its representatives].</i></p> <p>(e) for loss or damage to materials on-site and for which payment have been included in the Interim Payment Certificate, where applicable.</p>



	<p>The Contractor shall choose to take the insurance covers indicated above as separate covers or a combination of the Contractor’s All Risks coupled with the Employer’s liability and First Loss Burglary, after approval of the Employer. All insurance covers shall be of nil or the minimum possible deductibles at sole expense of the contractor.</p> <p><b><u>The insurance policies shall be extended to cover for any extension of the intended completion date or due to delay by the contractor up to the end of the defects liability period of the works.</u></b></p>
GCC 14.1	<p><b>Site Data are: There are no site investigation reports for this project. The contractor is advised to visit the site and acquaint himself with the site conditions, nature of soil, means of access and other factors which may affect the offer.</b></p> <p><b>No claim due to ignorance of these factors shall be entertained from the contractor.</b></p>
GCC 20.1	<p>The Site Possession Date(s) shall be: <i>on the day of the handing over of site which will be communicated to the contractor after receiving the Insurance Covers &amp; Performance Security as per requirements.</i></p>
GCC 23.1 & GCC 23.2	<p>Appointing Authority for the Adjudicator: <b>No Adjudicator shall be appointed for this Contract.</b></p>
GCC 24.	<p>In case a dispute of any kind arises between the Employer and the Contractor in connection with, or arising out of, the contract or the execution of works or after completion of works and whether before or after repudiation or other termination of Contract, including any dispute as to any opinion, instruction, determination, certificate or valuation of the Employer’s Representative, the matter in dispute shall, in the first place, be referred in writing to the employer’s representative, with a copy to the other party.</p> <p>The Employer and the Contractor shall make every effort to resolve the dispute amicably by direct informal negotiation. If, after twenty-eight (28) days, the parties have failed to resolve their dispute or difference by such mutual consultation, then either the Public Body or the Contractor may give notice to the other party of its intention to refer the matter to:</p> <p>“ the competent courts of Mauritius”</p>

<b>GCC 24.3</b>	Hourly rate and types of reimbursable expenses to be paid to the Adjudicator: <b>Not applicable.</b>
<b>GCC 24.4</b>	<p><i>For large contracts with domestic contractor or for contract with foreign contractor:</i></p> <p>Any dispute or difference in respect of which a notice of intention to commence arbitration has been given shall be finally settled by arbitration in accordance with Mauritian Laws by an Arbitrator to be appointed by both parties to the dispute or in any case of disagreement, by an Arbitrator to be appointed by a judge in Chambers of Mauritius. The Arbitrator fees will be borne by the losing party. Any decision of the Arbitrator shall be final and binding to both parties”.</p> <p><b>Not Applicable</b></p>
<b>B. Time Control</b>	
<b>GCC 25.1</b>	The Contractor shall submit for approval a Program for the Works within 21 days from the date of the Letter of Acceptance.
<b>GCC 25.3</b>	<p>The period between Program updates is <b>14 days</b>.</p> <p>The amount to be withheld for late submission of an updated Program is <b>Rs25,000.00</b>.</p>
<b>C. Quality Control</b>	
<b>GCC 33.1</b>	The Defects Liability Period is: <b>365 days</b> .
<b>GCC 39.7</b>	Interim Payment for Plant and Material on site <b>is</b> applicable.
<b>D. Cost Control</b>	
<b>GCC 41.1 (l)</b>	<p>The term “exceptionally adverse weather conditions” is hereby defined as any one of the following events:</p> <ol style="list-style-type: none"> <li>(1) 100 mm rainfall or above recorded in one day at the nearest rain station;</li> <li>(2) An official declaration of “Torrential Rain” by the Meteorological Department of Mauritius; and</li> </ol>

	(3) Cyclone warning Class II or above.
<b>GCC 43.1</b>	The currency of the Employer's country is: <b>Mauritian Rupees.</b>
<b>GCC 44.1</b>	The Contract <b>is not</b> subject to price adjustment in accordance with GCC Clause 44, and the following information regarding coefficients <b>does not apply.</b>
<b>GCC 45.1</b>	The proportion of payments retained is: <b>10%</b>
<b>GCC 46.1</b>	The liquidated damages for the whole of the Works are <b>Rupees Fourteen Thousand (Rs 14,000) per day.</b>  The maximum amount of liquidated damages for the whole of the Works is <b>Rupees Eight Hundred and Forty Thousand ( Rs 840,000)</b>
<b>GCC 47.1</b>	<i>Not Applicable.</i>
<b>GCC 48.1</b>	The Advance Payments shall be: <i>10 % maximum of the contract price less all prime cost, provisional sums and contingency sum and shall be paid to the contractor no later than twenty-eight (28) days from the date of issue of certificate. The Advance Payment shall be recovered through Contractors running account bills at the rate of 12.5% of the gross value of works done including materials on site.</i>
<b>GCC 49.1</b>	The Performance Security amount is  (a) <b>Bank Guarantee: 10% of the Contract Price inclusive of provisional and contingencies sum and VAT issued by a commercial bank operating in Mauritius, as per the format in Section VIII and shall be valid until the end of the defects liability period.</b>  <i>Where the Performance Security and the insurance policies expire before the end of the date of completion of works, the contractor shall renew same to cover the period up to completion of the works and shall extend these to cover the end of the defects liability period at no extra cost. The Contractor shall inform in writing of the steps taken.</i>  <i>Failure on the part of the contractor to comply with the above condition may entail:</i>  (i) <i>Non-certification of payments</i>  (ii) <i>Termination of the contract</i>  (iii) <i>Forfeiture of the amount of Performance Security.</i>  <i>condition may entail:</i>

	<p>(i) <i>Non-certification of payments</i></p> <p>(ii) <i>Termination of the contract</i></p>
<b>E. Finishing the Contract</b>	
<b>GCC 55.1</b>	<p>The date by which operating and maintenance manuals are required is as requested by Project Manager</p> <p>The date by which “as built” drawings are required is required is as requested by Project Manager.</p>
<b>GCC 55.2</b>	<p>The amount to be withheld for failing to produce “as built” drawings and/or operating and maintenance manuals by the date required in GCC 58.1 is</p> <p><b>Rs 25,000</b></p>
<b>GCC 57.2 (g)</b>	The maximum number of days is: <b>60 Days</b>
<b>GCC 59.1</b>	The percentage to apply to the value of the work not completed, representing the Employer’s additional cost for completing the Works, is <i>twenty percent (20%)</i> .

---

## **Section VIII - Contract Forms**

This Section contains forms which, once completed, will form part of the Contract. The forms for Performance Security and Advance Payment Security, when required, shall only be completed by the successful Bidder after contract award.

### **Table of Forms**

<b>Letter of Acceptance .....</b>	<b>136</b>
<b>Contract Agreement .....</b>	<b>137</b>
<b>Sample Form of Preference Security .....</b>	<b>139</b>
<b>Advance Payment Security .....</b>	<b>140</b>

# Letter of Acceptance

*[ on letterhead paper of the Employer]*

..... *[date]* .....

To: ..... *[ name and address of the Contractor]* .....

Subject: ..... *[Notification of Award Contract No]* .....

This is to notify you that your Bid dated . . . . *[insert date]* . . . . for execution of the . . . .  
. . . . .*[insert name of the contract and identification number, as given in the Appendix to Bid]* .  
. . . . . for the Accepted Contract Amount of the equivalent of . . . . . *[insert amount in numbers and words and name of currency]*, as corrected and modified in accordance with the Instructions to Bidders is hereby accepted by *(insert name of Public Body)*.

You are requested to furnish the Performance Security within 21 days in accordance with the General Conditions of Contract, using for that purpose of the Performance Security Form included in Section VI (Contract Forms) of the Bidding Document.

Authorized Signature: .....

Name and Title of Signatory: .....

Name of Agency: .....

Attachment: Contract Agreement

## Contract Agreement

THIS AGREEMENT made the . . . . .day of . . . . ., . . . . ., between . . . . . [name of the Employer]. . . . . (hereinafter “the Employer”), of the one part, and . . . . . [name of the Contractor]. . . . . (hereinafter “the Contractor”), of the other part:

WHEREAS the Employer desires that the Works known as . . . . . [name of the Contract]. . . . . should be executed by the Contractor, and has accepted a Bid by the Contractor for the execution and completion of these Works and the remedying of any defects therein,

The Employer and the Contractor agree as follows:

1. In this Agreement words and expressions shall have the same meanings as are respectively assigned to them in the Contract documents referred to.
2. The following documents shall be deemed to form and be read and construed as part of this Agreement. This Agreement shall prevail over all other Contract documents.
  - (a) the Letter of Acceptance
  - (b) the Bid
  - (c) the Addenda Nos . . . . . [insert addenda numbers if any]. . . . .
  - (d) the Appendix to the General Conditions of Contract
  - (e) the General Conditions of Contract;
  - (f) the Specification
  - (g) the Drawings; and
  - (h) the completed Schedules,
3. In consideration of the payments to be made by the Employer to the Contractor as indicated in this Agreement, the Contractor hereby covenants with the Employer to execute the Works and to remedy defects therein in conformity in all respects with the provisions of the Contract.
4. The Employer hereby covenants to pay the Contractor in consideration of the execution and completion of the Works and the remedying of defects therein, the Contract Price or such other sum as may become payable under the provisions of the Contract at the times and in the manner prescribed by the Contract.

IN WITNESS whereof the parties hereto have caused this Agreement to be executed in accordance with the laws of Mauritius on the day, month and year indicated above.

Signed by: \_\_\_\_\_  
for and on behalf of the Employer

Signed by: \_\_\_\_\_  
for and on behalf the Contractor

in the  
presence of: \_\_\_\_\_  
Witness, Name, Signature, Address, Date

in the  
presence of: \_\_\_\_\_  
Witness, Name, Signature, Address, Date



## Sample Form of Preference Security

### Form of Preference Security (Bank Guarantee)

To: \_\_\_\_\_ [*name of Employer*]  
 \_\_\_\_\_ [*address of Employer*]

WHEREAS \_\_\_\_\_ [*name and addresses of the contractor*] (hereinafter called "the Contractor"), has undertaken in pursuance to Contract No. \_\_\_\_\_ dated \_\_\_\_\_ to execute \_\_\_\_\_ [*name of Contract and brief Description of Works*], (hereinafter called "the Contract");

AND WHEREAS it has been stipulated by you in the said Contract that the Contractor shall furnish you with a Bank Guarantee by a local commercial bank for the sum specified therein as security for compliance with his obligation stated in Sub-Clause 49.2 of the Conditions of Contract;

AND WHEREAS we have agreed to give the Contractor such a Bank Guarantee;

NOW THEREFORE we hereby affirm that we are the Guarantor and responsible to you, on behalf of the Contractor, up to a total of \_\_\_\_\_ [*amount of Guarantee*]<sup>8</sup>, we undertake to pay you, upon your first written demand and without your having to substantiate such demand any sum within the limit of \_\_\_\_\_ [*amount of Guarantee*].<sup>1</sup>

We hereby waive the necessity of demanding the said debt from the Contractor before presenting us with the demand.

We further agree that no change or addition to or other modification of the terms of the Contract or of the Works to be performed thereunder or of any of the Contract documents which may be made between you and the Contractor shall in anyway release us from liability under this guarantee, and we hereby waive notice of any such change, addition or modification.

This guarantee is valid until the date of the Completion Certificate.

Signature and Seal of the Guarantor \_\_\_\_\_  
 Name of Bank \_\_\_\_\_  
 Address \_\_\_\_\_  
 Date \_\_\_\_\_

<sup>8</sup> Amount to be inserted by the Guarantor in accordance with Sub-Clause 49.2 of the General Conditions of Contract

## Advance Payment Security

*[Bank's Name, and Address of Issuing Branch or Office]*

**Beneficiary:** ..... *[Name and Address of Employer]* .....

**Date:** .....

**Advance Payment Guarantee No.:** .....

We have been informed that . . . . . *[name of the Contractor]*. . . . . (hereinafter called “the Contractor”) has entered into Contract No. . . . . *[reference number of the Contract]*. . . . . dated . . . . . with you, for the execution of . . . . . *[name of contract and brief description of Works]*. . . . . (hereinafter called “the Contract”).

Furthermore, we understand that, according to the Conditions of the Contract, an advance payment in the sum . . . . . *[name of the currency and amount in figures]*<sup>1</sup>. . . . . (. . . . . *[amount in words]*. . . . . ) is to be made against an advance payment guarantee.

At the request of the Contractor, we . . . . . *[name of the Bank]*. . . . . hereby irrevocably undertake to pay you any sum or sums not exceeding in total an amount of . . . . . *[name of the currency and amount in figures]*\*. . . . . (. . . . . *[amount in words]*. . . . . ) upon receipt by us of your first demand in writing accompanied by a written statement stating that the Contractor is in breach of its obligation under the Contract because the Contractor used the advance payment for purposes other than the costs of mobilization in respect of the Works.

It is a condition for any claim and payment under this guarantee to be made that the advance payment referred to above must have been received by the Contractor on its account number . . . . . *[Contractor's account number]*. . . . . at . . . . . *[name and address of the Bank]*. . . . .

The maximum amount of this guarantee shall be progressively reduced by the amount of the advance payment repaid by the Contractor as indicated in copies of interim statements or payment certificates which shall be presented to us. This guarantee shall expire, at the latest, upon our receipt of a copy of the interim payment certificate indicating that eighty (80) percent of the Contract Price has been certified for payment, or on the . . . day of . . . . . , . . . . .<sup>2</sup>, whichever is earlier. Consequently, any demand for payment under this guarantee must be received by us at this office on or before that date.

..... *[Seal of Bank and Signature(s)]* .....

### **Note –**

*All italicized text is for guidance on how to prepare this demand guarantee and shall be deleted from the final document.*

*1 The Guarantor shall insert an amount representing the amount of the advance payment denominated either in the currency(ies) of the advance payment as specified in the Contract, or in a freely convertible currency acceptable to the Employer.*

*2 Insert the expected expiration date of the Time for Completion. The Employer should note that in the event of an extension of the time for completion of the Contract, the Employer would need to request an*

*extension of this guarantee from the Guarantor. Such request must be in writing and must be made prior to the expiration date established in the guarantee. In preparing this guarantee, the Employer might consider adding the following text to the form, at the end of the penultimate paragraph: “The Guarantor agrees to a one-time extension of this guarantee for a period not to exceed [six months][one year], in response to the Employer’s written request for such extension, such request to be presented to the Guarantor before the expiry of the guarantee*

**GOVERNMENT OF MAURITIUS**

**STANDARD SPECIFICATIONS**

## **STANDARD SPECIFICATIONS**

### **INDEX**

<b><u>Description</u></b>	<b><u>Pages</u></b>
1. Concrete blocklayer	2
2. Mason	4
3. Carpenter and joinery	5
4. Ironmonger, smith and metal worker	8
5. Pavior	9
6. Plasterer and wall tiler	11
7. Glazier	13
8. Painter and decorator	14
9. Plumber	16
10. Drainlayer	19
11. Roads and footpaths	21

### **SPECIFICATIONS FOR REINFORCED CONCRETE WORK**

12. General	-
13. Excavation	22
14. Concrete work	24
15. Concrete strengths	26
16. Construction joints	30
17. Expansion/contraction joint	31
18. Water bars	31
19. Embedded items in concrete	32
20. Placing concrete	32
21. Compaction of concrete	34
22. Curing and protection	35
23. Faulty concrete	35
24. Reinforcements	35
25. Chase, holes etc in concrete	37
26. Position of electrical conduit	38
27. Formwork	38
28. Precast concrete	40
29. Composite floor slabs	41
30. Notes concerning measurement and pricing	42
31. Index for reinforced concrete work	44

Note: Page 51 omitted

**CONCRETE BLOCKLAYER**

**Concrete blocks**

Concrete blocks for walling shall comply with B.S 2028 Type A (for load bearing walls) and of compressive strength not less than:

Cavern of 12 blocks .....500 lbs/sq.in  
Gross area  
Lowest individual block ....375 lbs/sq.in  
Gross area

Blocks for non load bearing walls are to be class B blocks.

Blocks shall be hollow two-hole type and shall be cured for not less than 28 days before they are used in the works. The Contractor shall supply a certificate from the supplier for each consignment of block received to the effect that the blocks meet the requirements and strength of the latest relevant B.S. Any block for which a certificate cannot be produced will be condemned and must be removed from site. All blocks supplied shall be of the same height and blocks of similar dimensions will not be accepted. Half length blocks and specials shall also be provided as specified or required to break bond.

**Mortar**

Mortar to be used for all Type A blockwall shall be composed of 1 part of cement to 3 parts of sand. Mortar for Type B blockwork shall be composed of one part of Portland cement, one part lime, and five parts of sand. All mortar shall be measured in specially prepared gauge boxes and thoroughly mixed dry or clean and water tight mixing platforms, with water added from a fine rose until all parts are completely incorporated and brought to a proper consistency.

All mortar must be used within thirty minutes of mixing. No partially or Wholly set mortar will be allowed to be used or re-mixed.

**Setting and jointing**

All blocks shall be lightly wetted immediately before being bedded and jointed to minimise absorption of water from the mortar.

Blocks are to be well buttered with mortar as previously specified. The blocks shall be laid fir-faces on the outside face, in stretcher bond with 10mm, thick, full, flused up and grouted solid joints. The joints shall not vary by more than 3mm and four consecutive joints shall not exceed 38mm and four consecutive joints shall not exceed 38mm. Joints shall be raked out where surfaces of walling are to be plastered.

**Laying of blocks**

All walls throughout the work shall be carried up evenly in courses, no part being allowed to be carried up more than 900 mm. higher at one time than any other part and in such cases the joining shall be made in long steps so as to prevent cracks arising and all walls shall be levelled around at each floor.

All put log holes shall be carefully, properly and completely filled up on completion of walling work.

All walling shall be properly protected while mortar is setting.

Walls shall be kept thoroughly wet for at least three days or for such longer period of time as the Architect may direct. Walls exposed to the sun shall be protected with a sacking which shall be kept wet.

Fair Face Blocks

Where walling is to be finished fairfaced, the blocks are to be selected free from defects. Joints shall be raked out as works proceed and pointed with a neat flush joint.

The work shall be carried out regularly with all horizontal joints truly horizontal and no part shall be more than 900mm above adjacent work during construction.

Sample Panel

The Contractor shall include in his tender for erecting a sample panel on site of 200mm blockwork, not less than 1 square metre in area and built off a suitable concrete foundation. The sample, when approved, to form the standard for all concrete blockwork in the contract. The sample area and concrete foundation to be removed when ordered and the surface of the ground made good. Horizontal and vertical joints shall be 10mm finished thickness, and raked out 12mm deep where face of wall is to be rendered and in other cases to be left finished flush or as otherwise instructed. The joint grooves between blocks shall be completely filled with cement, lime mortar. No portion of the wall during construction to be more than 900mm above adjoining work. All work to be executed truly level, perpendicular and properly bonded together without continuous upright joints.

Cement, sand and lime

Cement and aggregates for this trade except where separately specified for precise concrete blocks shall be as specified for "concretor" and lime shall be dry hydrated lime to B.S 890 Class B.

Air bricks

Form and leave neat holes in walls and supply and build in approved loucred pattern concrete air bricks where shown. The opening shall be rendered on all sides, the bottom sloped towards external face.

Bedding and pointing

Bedding and pointing of timber door and window frames shall be in cement mortar. Where frames are in metal they shall be bedded and pointed in mastic. Lugs or ties shall be built into walls as described.

Fixing blocks and  
and leaving holes

Provide and build into walls all necessary flying blocks and leave out or cut away as necessary holes for pipes, conduits and the like and make good after fixing by other trades and specialists.

Build in lugs  
and the like

Form or leave mortices in walls for, and build in lugs and all necessary fixing for metal windows and doors, door frames and lining, sanitary fittings, rainwater pipes, clips and bearer of various types.

When building up the walls the openings shall be made about 200mm wider than the external dimensions of the doors frames, and when the latter are placed, complete with lugs, the walling completed in concrete mix type C.

Damp-proof course

Where indicated on drawings provide 2-ply felt damp-proof course. Felt to be of a manufacture approved by the Architect and to be laid on a 25mm thick bed of cement mortar (1:3 mix) on walls.

The damp-proof courses to stand the full thickness of walls, partitions and beams in one width and to be overlapped 6" at all jointings and corners.

Measurements

The Contractor must allow in his prices for block walling for plumbing angles, all straight waste, split courses necessary for bond, bonding at angles, intersections and junctions of walling at angles, intersections and junctions of walling of different thicknesses, cutting and fitting to columns, cutting and pinning to beam, cutting and fitting around end of oils and lintols, cutting and pinning ends of structural timber.

The rates of blockwork must also include for fixing all door, window and like openings, forming reveals to same and for cutting and waste to walling in short lengths to millions and jamb of openings.

The rates of blockwork must also include for hoisting and building off beams and slab at any level, all necessary scaffolding and for work built overhead.

**Mason**

Cement and sand

Cement and sand for this trade shall be as specified for contractor.

Mortar for masonry work

Mortar for bedding and jointing of stonework shall comprise 1 part of cement to 3 parts of sand by volume.

Stonework in walls

All stones for use in walling shall be blue basalt stone carefully selected according to the type of walling required. Walls to be built to the thickness shown on the drawings and the stones wall be well bonded and all voids filled in solid with mortar, bond stones to be used on every 120mm vertically and 2700mm horizontally.

Mortar joints shall be raked to depth of 12mm from face of stonework ready for painting. Walls exposed to sun shall be protected with sacking which shall be kept thoroughly wet for at least three days or for such longer period of time as the Architect may direct.



Pointing All joints shall be raked out as described in Clause 3 and pointed with cement and sand (1:3) with approved pigment added. The pointing will either be recessed, weather struck or flush.

Cleaning of stonework The contractor shall protect the stonework from mortar droppings and wire brush and wash down all walls on completion.

### **Carpenter and Joinery**

1. Timber generally All timbers used in the works unless otherwise specified shall be one of the following:

(a) For constructional work keruing, gurjun, mahogany or approved local treated pine.

(b) For joinery work, mahogany, tekoma, teak

The timber shall be sound, selected, well seasoned vacuum impregnated With Tanalith Salts type C at the rate of 64 kgs per cu.m. of timber, free from all defects and shall be worked to the full sizes indicated on the drawings.

In all cases samples of the timber for use in the building shall be submitted to the Architect for approval prior to use.

2. Treatment of timber The ends and backs of all doors, frames of all timbers built in, resting or Indirect contact with walling or concrete where not exposed to view, shall be coated with two coats of creosote, solignum or other approved preservative.

3. Replacement of defective timber Should any of the timber warp, shrink, wind or fly to any appreciable extent within 6 months of completion of the works, the same shall be removed and new fixed in its place at the contractor's sole expense together with all other work that may be affected.

4. Preparation of timber The preparation of the timber shall commence simultaneously with the beginning of the work generally and shall proceed continuously until the whole of the woodwork is prepared and stacked on the site, and properly protected from the weather.

5. Constructional timber All constructional timber shall be properly jointed and framed together with dowels, bolts or spiked as indicated on the drawings.

6. Workmanship All carpentry shall be executed with workmanship of the best quality. All carpenter's work shall be left with sawn surface except where specified to be wrot.

- 6 -

All carpenter's work shall be accurately set out and in strict accordance with the drawings and shall be framed together and securely fixed in the best possible manner with properly made joints. Provide all brads, nails, screws etc as necessary and as directed and approved.

All timber shall be as long as possible and practicable, in order to eliminate joints.

Actual dimensions of scantlings for carpentry shall not vary from the specified dimensions by more than 3 mm in deficiency or excess.

7. Protect floors

All timber bearded floors to be protected with sawdust after laying. The sawdust to be cleared away on completion.

8. Joinery work generally

All joiner's work generally to be cast and framed together as soon as is practicable after the commencement of the building, but shall not be wedged or glued until the building is ready for fixing same.

All work to be properly tenoned, shouldered, wedged, pinned, bradded etc. as directed by and to the satisfaction of the Architect and all properly glued up with best quality approved glue.

Oval or round brads or nails shall be used for fixing on face work, heads properly punched in and the holes filled with putty or as otherwise described.

9. Finish to

All exposed faces of woodwork shall be wrot, which shall mean bringing up the surface after planing with sand paper to a smooth satin-like finish.

10. Workmanship

All joinery work shall be executed with workmanship of the best quality in strict accordance with the detailed drawings.

All joiner's work shall be accurately set out on boards to full size for information and guidance of artisans before commencing the respective work. All joints, ironwork and other work connected therewith fully declined which said setting out will be required to be submitted to the Architect and approved before such respective works are commenced.

All mouldings shall be accurately and truly run and all work planned and finished to the approval of the Architect. All arises to be slightly rounded.

Should any of the joinery work shrink, warp, wind or develop other defects within six months after the completion of the works, the same will be removed and now fixed in its place, together with all other work which may be affected thereby, at the contractor's cost and expense.

All plugs described as fixing for joinery etc. unless otherwise stated shall be formed by raw plastic Philplug screwfix or other approved patent material. No woodplugs shall be used.

Any fixed joinery which in the opinion of the Architect is liable to become bruised or damaged in any way shall be properly cased and protected by the contractor until the completion of the works.

11. Door frames

Door frames and linings shall be constructed to the sizes and details shown on the drawings. Door frames shall be fitted with three fixing irons to each side of the frame and one at the head. Frames for double

doors shall have two fixing at the head. The fixing irons shall consist of 300mm long heep iron not less than 3 mm thick bent up 75mm at one

end and twice screwed to the frame and the other end built into walls or cast into the lintols to a depth of 225mm (where lintols are less than 225mm deep the straps shall be cut off to the full depth of the lintol). 6mm diameter metal dowels shall be fixed to each end of the frame and let into the floor concrete to a depth of at least 50mm.

Door linings shall be screwed to wooden fixing slips let into the walls And lintols.

12. Doors

Doors shall be provided and fixed to the sizes and details shown on the drawings. Doors shall be free from all blemishes and shall be rubbed down to a satin-like finish. Frames, ledged and braced or ledged and braced doors shall be made to the sizes shown on the drawings and the nailing in construction shall be driven from the face and clenched at the back. The heads of nails shall be punched and the holes filled with petty.

The flush doors are to be equal in all respects to the samples of each type to be submitted to the Architect for approval. The coves of all doors shall be pressure bonded and stacked for inspection before the faces are fixed. The plywood facings shall be of the same species on both sides of each door unless otherwise stated.

Facings shall be free from lifting at edges, blisterings or sinking or raising of the surface due to defects in the base of materials.

13. Hardboard

Hardboard shown on drawings for linings, ceilings and joinery shall be of approved manufacture.

14. Veneered plywood

All veneered plywood or blockboard is to be counter-veneered on the reverse side. Plastic faced material shall also be counter-veneered if and where necessary.

15. Formica Formica shall be as supplied by Messrs Formica Ltd. De la Rue House, 84 Regent Street, London W.I., England or similar approved, of approved colour and pattern and fixed with an approved adhesive in accordance with the manufacturer's instructions.
16. Ironmongery Butts and hinger shall be of sizes and types specified and fixed with the full number of screws and on no account shall nails be used.
- All locks and ironmongery shall be fixed before the woodwork or metal work is painted. Handles shall be removed carefully stored and re-fixed after the completion of painting. Locks shall be oiled and left in perfect working order. All locks to include two keys and all keys shall be labelled with door references marked on plastic labels before handing to the Architect on completion.
17. Plugging and screwing Where items are described as plugged or plugged and screwed this shall mean plugging, plugging and screwing to concrete blockwalling, concrete walling, stone walling to the approval of the Architect.
18. Prices of timber work The Contractor is to include in his prices of all members for fitted ends, nitres, housings, returned ends, etc. and for short-lengths not exceeding 300mm.
- The prices for all joinery items are to include for slightly rounding all arises and extra cost of labours crossgrain.
- Where hardwood is described as screwed, prices are to include for pollating with a natching hardwood.
- Allowance is to be made in the prices for angles, ramps, nitres, ends, etc. on timber worked on solid and shall include for all necessary non-ferrous metal screws.
- The prices for all timber described as select quality are to allow for keeping clean for light coloured finishes, polishings, etc.

**Ironmonger, stitch and metalworker**

1. Ironmongery All ironmongery and furniture to be approved by the Architect as to quality and type and locks to be fixed to the correct hand.
2. Oiling of locks, etc. All locks, ironmongery and hinges including the moving parts of metal doors and windows to be well oiled, and all necessary adjustment made before handing over the works.
3. Metal windows and doors All metal windows and doors shall be hot dipped galvanized after manufacture and shall be from a manufacturer approved by the Architect.

They shall be of sizes and types shown on the drawings and shall be ordered by the Contractor and windows shall have bronze fittings with projecting hinges unless otherwise specified complete with building in lugs and glazing pins. Metal doors and windows bent or damaged during construction of the building shall be replaced at the contractor's expense.

4. Cyclone bolts

All openings sashes of metal windows shall be fitted with two cyclone bolts consisting of an extruded brass case with stamped brass sheet 115mm long complete with socket or wedge,

5. Louvre windows

Louvre frames to be anodized aluminium with clips of the size specified suitable for taking 6mm thick glass blades screwed to concrete jambs with 38mm screws.

Mullions to be formed by coupling 56mm x 6mm thick anodized Aluminium mullion strips bolted through to the box mullions, and fix to lintol and cill by means of retaining brackets screwed to rawplugs in concrete with No. 4 38mm screws.

Weather strips to be in anodized aluminium and to be screwed to rawlplugs in concrete at head and cill with 38mm screws.

Workmanship

Workmanship and materials shall be of the best quality.

Prices of all doors, windows and louvers shall also include for all necessary cutting and pinning, plugging and screwing to concrete or block openings and for making good of finishes.

**Pavior**

1. Cement, sand and aggregate

Cement, sand and aggregates for this trade shall be as specified for "concretor".

Coral sand shall have three washings.

2. Preparation of surface to receive screedings and pavings

The surface of the concrete shall be hacked to form a good key, well washed and brushed perfectly clean with a wire brush to remove all impurities, dust etc damped and grouted with a mixture of cement and water in the form of slurry, using 2.75 kgs of cement per sq.m. of surface area, before screeds are laid.

3. Plain screeded pavings

Floors to have plain screeded finish shall be laid in areas not exceeding 10 sq.m at one time using teak 6mm x 19mm stop fillets. Screeds to be minimum of 19mm and to be composed of one part of cement to 3 parts of sand. The surface to be finished to a polished surface with a steel trowel. The screeds or pavings shall be kept wet with sand, sacking or similar for at least seven days after completion.

4. Coloured screeded pavings

Coloured screedings shall be laid in a similar manner as for plain screeding with addition of approved liquid colouring mixed in with the mortar strictly in accordance with the manufacturer's directions and to approved shade, and kept wet for seven days after completion.
5. Expansion joints

At the entrance of each room directly under the door, fix a teak strip 6mm x 19mm deep for full width of opening to form an expansion joint between adjoining screeds.
6. Granolithic paving

Shall be laid in areas not greater than 10 sq.m. at one time using teak 6mm x 19 mm fillets. Granolithic paving shall be composed of two parts by volume of cement to five of blue basalt chippings to pass a 6mm square mesh free from dust and containing not more than 10% grit. Granolithic paving to be well watered and kept damp for seven days after laying.
7. Polishing of granolithic pavings

When laid the Granolithic paving shall be rubbed down with a carborundum stone to give polished surface.
8. Non-slip surfaces to pavings

Surfaces of internal pavings and steps where required to be made non-slippery shall be created with coarse carborundum average 11.4 kgs per m<sup>2</sup> lightly trowelled in while the paving is still green.

Surfaces of external pavings or steps where required to be made non-slippery shall have parallel lines 12mm deep and 9mm wide in the surfaces of the paving or concrete.
9. Quarry tiling

Quarry tiles shall be to the quality, sizes and colour as selected by the Architect, laid to areas indicated on the drawings. The tiles shall be set square jointed bedded and pointed in cement mortar (1 part of cement to 3 parts of sand).

Tiles shall be soaked in water 24 hours before laying and shall be thoroughly scrubbed to remove all traces of cement after laying and protected with sawdust or sacking and not used for at least 10 to 14 days.

The surface shall be polished on completion of the contact.
10. Polishing paved surfaces

Types of floors described in clauses 4 and 7 shall be cleaned on completion of the works and treated with two coats of floor polish each coat rubbed well in and polished.
11. Roof screed

Roof slabs shall be finished with a cement/sand screed 1:3 mix laid to falls and crossfalls and minimum thickness 19mm. unless specified otherwise in bill of quantities to which shall be added an approved water-proofing liquid used in strict accordance with the manufacturers' written instructions. Screeds shall be carried down rainwater outlets and finished neatly against the downpipe. The screed shall be kept wet for at least seven days after completion.

12. Prices of pavings and screeds tiles etc.

Prices for pavings or screeds are to include for preparation of the concrete base, all necessary hacking, grouting with cement grout, any extra thickness consequent upon the concrete surfaces not being finished to true and level, laying in bays and all necessary formwork and dividing strips and cutting the finished screed or paving for at least seven days.

Prices for tiling shall also include for all straight and raking cutting, fair edges and fair joint, prices for tile skirtings shall further include for angles, ends, nitres and for short lengths not exceeding 300mm.

**Plasterer and wall tiler**

Generally

The renderings are to be carried out so that the finished surfaces appear Without visible joints or patches. The rendering of wall surfaces, reveals of openings and cills are to be carried out in one operation and each day's work stopped at a suitable point where it can be picked up again on the following day without noticeable joints. The quality and mixing of the materials are to be constant throughout so that there is no variation in colour or texture. The finished coat to be brushed down and left clean to be received decoration. In any continuous face of a wall the rendering shall be carried out continuously and day to day breaks made to coincide with architectural breaks in order to avoid unsightly junctions.

Preparation of surfaces for rendering

All faces of concrete work shall be well hacked to form a good key and in the case of block or stone walls the joints shall be raked out. All surfaces for rendering shall be well wetted with a hose before rendering is applied

Cement

Cement shall be as specified in "concretor".

Sand

Sand shall be as specified in Fine Aggregates in "Concretor" but in Addition shall be in accordance with B.S. 1199 and shall if CORAL SAND have three washings in lieu of 2 for internal work.

Lime

Lime shall be either in the form of quick lime and obtained from an approved source and properly stacked on site or in the form of dry hydrated lime and conform to the requirements of B.S 890 Class B "Quick lime or Hydrated Lime for Corse Stuff and Building Mortar".

Rendering

The mix for rendering both internally and externally shall be 1 part of Cement to 1 part of lime to 5 parts of sand plus an approved mortar plasticizer used strictly in accordance with the manufacturers' written instructions.

Application of Rendering

All external surfaces shall be rendered in two coats unless otherwise instructed.

- 12 -

The first coat of rendering shall be applied with wooden float to an even thickness of not less than 10mm and not more than 15mm. As soon as the first coat starts to set it shall be closely combed to a depth of 3mm to 6mm and kept damp for at least two days after which time the final coat shall be two days after which time the final coat shall be applied to an even thickness of not less than 6mm and not more than 25mm.

All rendered surfaces shall be kept damp for at least two days after the final coat has been applied.

Finishes to renderings

Rendered surfaces shall be finished as directed by the Architect in the following manner:

- (a) Wood floor finish: Finish surfaces with a wood float to an even and slightly/rough textured finish.
- (b) Sponge finish: Finish rendered surfaces with a steel trowel and while the rendering is still green dab the surfaces with a damp sponge until they present a fairly sanded textured finish.
- (c) Trowel finish: Finish rendered surfaces with a steel trowel to a smooth and even surface, free from trowel marks.

Tyrolean Finish

Tyrolean rendering shall consist of a 12mm backing coat of one part of cement with 10% of lime by volume added to four parts of sand, trowelled up to a true surface left as open as possible (no combing or scratching required) followed by a tyrolean finishing coat of white cement (snowcrete or other equal, and sand of a suitable mix applied with a spraying machine and built up in three coats to a total thickness of 8mm approximately to the approval of the Architect.

Sample panel

The Contractor shall prepare samples of plastering tyrolean finish, bush-hammered finish as directed until the quality texture and finish required is obtained and approved by the Architect, after which all plastering, tyrolean and bush hammered finish expected in the work shall conform to the respective approved samples.

Arrises

Vertical and horizontal arrises shall be formed to beams, columns, openings and the like and shall be pencil rounded. Particular care shall be taken to ensure that the rendering is strong and sound at the corners.

Cracks, blisters, etc

The Contractor shall make good all cracks, blisters and other defects and leave the whole of the plaster, tyrolean, bush-hammered finish perfect at completion. When making good defects the plaster shall be cut out to a rectangular shape with edges undercut to form dove-fitted key and all finish flush with face of surrounding plaster all at the contractor's own expense.



Plinths

Form plinths is external rendering as shown on drawings.

Wall tiling

Wall tiling unless otherwise stated shall be of glazed earthenware tiles of The dimensions and colours specified and shall conform to B.S 1281 and shall be of approved manufacture true to shape and free from blemishes. The backing coat for wall tiling shall be in cement: sand mortar (1:2 dx) , not less than 9mm and not more than 15mm thick, the surface of which shall be closely combed while the mortar is still green and left for a period of 24 hours.

The tiles shall be soaked in water for 30 minutes and bedded with an Adhesive of the approved manufacture.

All tiles shall be laid perfectly level, the joints to run straight horizontally And vertically and to be pointed in neat cement to an approved colour.

Internal and external angles and rounded edges tiles are to be of the same manufacture, colour and thickness as the foregoing.

Prices of plasters.

Prices of plastering are to include for preparation of the surface, hacking of concrete, raking out joints of blockwork, grouting, forming temporary rules, fair edges and arrises, rounded external angles, vee joints, working to rebates making good to window or door frames, around pipes, holder-bats, sanitary fittings, narrow widths and small quantities.

Prices for rendering on walls shall also include for any extra labour involved in working to breaking columns, beams, cills, etc, all of which have been included in the general term of walls.

Prices for wall tiling shall include for all operations required in proper execution of the work out and waste and fixing as described.

**Glazier**

Quality of glass

All the glass to be of the best quality obtained free from all defects and Imperfections and shall be to the approval of the Architect.

Windows and doors

Glaze all windows and doors in 4.5mm thick clear sheet glass unless specified otherwise.

Translucent glass

Windows requiring obscure vision shall be glazed with translucent glass of an approved texture or pattern, the thickness to be not less than that mentioned above unless specified otherwise.

Putty

Putty for glazing to wood shall be made of pure whiting and raw linseed oil and to be used fresh. Putty for glazing to metal shall be steel sash putty of approved manufacture.

All putty shall be delivered on site in the original manufacturer's sealed cans or drums and used direct therefrom, with the addition only of pure linseed oil if necessary. No mineral or other oils shall be used in the putties except genuine linseed oil.

The rebates of metal window shall be painted one coat before puttying.

Glazing

All glass to be cut accurately in one piece, to fit easily into their rebates and to be well puttied, back puttied and secured with springs in the case of fixing to wood or with metal clips in the case of metal. Care must be taken to ensure that the putty does not show beyond the sight lines of panes and that the putty is neatly cut off internally and neatly splayed off externally all mitres and angles left clear and sharp.

Glass blades for  
louvre window

Blades for louvre windows shall be 6mm thick glass of selected glazing quality Grade 'A' to B.S 952 and of approved manufacture.

The two long edges of the blades shall be flat smooth polished with no sharp arrises and the two others clean cut. The contractor shall, when requested to do so, produce certificates of proof of manufacture and quality of the glass blades he proposes to use.

Glazing work at  
completion

All glass broken, cracked or scratched during the progress of the works to be reinstated at the sole cost of the contractor and all glazing to be left clean and perfect at the completion of the contract.

**Painter & Decorator**

Generally

All work shall be carried out in strict accordance with schedule of colours to be obtained from the Architect.

Samples of colours if requested by the Architect shall be painted on the walls 1.00m x 1.00m square and approval obtained from the Architect before proceeding with the work.

Materials, paint,  
Varnishes, etc

All oil paints, emulsion paints, varnish and other materials shall be of an approved manufacture and shall be used strictly in accordance with the manufacturers' printed instructions, the contractor will only be allowed to use materials which are brought to the site in sealed cans not exceeding one gallon capacity, bearing the name of the manufacturer and properly labelled as to quality. Exterior quality paints only shall be used, both internally and externally. All cans of paint must be kept well stirred before and during use. The only addition to the paint which will be allowed shall be approved pure turpentine and this shall be added only in accordance with the Architect's instructions. All coats of paint applied over each other shall be from the same manufacture and the type recommended by the manufacturers.

Well before commencing the painting work the contractor shall submit to the Architect for approval a list of all the brands of paint and finishings including the necessary primers and undercoats he intends to use and immediately upon being so approved orders shall be placed and total requirements obtained for the works.

Once approved no other brand of materials shall be used without the express permission of the Architect in writing.

Preparation of Surfaces

All surfaces to be painted shall be thoroughly cleaned down and surfaces of wood to be sand-papered and to be twice knotted and stopped before applying the priming coat which shall be regarded as additional to the undercoat. All surfaces of ironwork to be thoroughly cleaned of all scale, and every particle of rust, dirt or grease removed by scrapers' and wire brushes, or other approved method. Galvanized, sheradised or zinc sprayed metal to be painted shall be treated with mordant solution. Copper pipes specified to be painted shall be rubbed down with coarse emery, cleaned with a solution of one part acetone to two parts of benzol and left to dry.

Wood Preservative

Treat all timber built in or in contact with walling and concrete with 2 coats of approved type of wood preservative.

Galvanised metal Surfaces

Clean down, treat with degreasing solution, prime with yellow chromate or other approved primer, and paint two undercoats and one gloss finishing coat oil paint.

Ironwork

Clean down, removing every trace of rust and paint 1 coat of red lead primer, 2 coats of undercoat and one gloss finishing coat.

Rendered surfaces

Brush down to remove dirt and dust, prime with alkali resistant primer as specified by the suppliers of the emulsion paint to be used and paint three coats of approved plastic emulsion paint (external quality) both internally and externally strictly in accordance with manufacturers' instructions. The walls are not to be pumiced down.

Cleaning on completion

All floors to be twice washed, all marks of paint to be sponged off, windows cleaned, the work generally to be touched up after all the other trades are finished and the whole of the building left clean and perfect on completion to the satisfaction of the Architect.

Laboratory furniture and wall cupboard, workbench

All laboratory furniture are to be finished with one coat polyurethane lacquer of approved manufacturer. The first coat is to be gloss lacquer thinned with 10% white spirit and applied to all surfaces including the back of fittings, inside of drawers, and doors, etc. All exposed surfaces are to be finished with a further coat of semi-gloss lacquer. Hardwood bench tops are to be finished with two coats of linseed oil.

### **Plumber**

#### **General**

All materials and workmanship shall comply with the latest editions of The British Standards's Specification, Codes of Practice, By Laws and Regulations of all Statutory Authorities concerned.

The Contractor shall include for producing all working drawings, details, builder's work and holes drawings necessary to carry out the work and as required by the Architect. The drawings shall be based upon the Architects diagrammatic drawings and shall be submitted, in duplicate progressively at least two months prior to the programmed commencement of work coordination and approval of the Architect. All alterations to drawings, whether due to co-ordinations or otherwise, shall be carried out by the contractor. The contractor shall provide the Architect with four copies of each approved drawings in addition to those required for his own use.

At completions of the contract, the Contractor shall provide the Architect With one complete set of negatives indicating the "As installed" installation and three prints of the said drawings complete with all operational and maintenance instructions, value charts, and test certificates. These drawings shall be provided to the Architect at practical completion of the works, failing which the Architect reserves the right to withhold an appropriate portion of the first retention money.

All work shall be tested in sections as required and before being covered up, for the Architect and statutory authorities. Before any test is carried out, a minimum of seven days notice shall be given to the Architect.

Where access is indicated to soil, waste and rainwater pipe fittings, the Contractor shall ensure that all access doors and rodding eyes are so positioned as to be accessible. Before testing, all access doors shall be removed, inspected, the washer greased and then reassembled by the Contractor.

#### **Lead in flats flashings, aprons etc.**

The lead used shall be best milled sheet lead of approved manufacture. No solder to be used in laying of lead except where quite unavoidable and no continuous strip of lead to be more than 2.00m long. Overlaps to be not less than 75mm. Lead flashings, aprons, soakers and other lead work where required to be fixed shall be secured with copper nails. Leadwork shall comply with the following weights.

	<u>Per sq.ft</u>
Lead gutters & flats	29.3 kgs
Flashings and aprons	24.4 kgs
Soakers	19.5 kgs

Soil ventilating pipes

Soil ventilating pipes shall be not less than 63mm interval diameter cast iron pipes conforming to B.S.S and fitted with the necessary junctions and bends. All joints shall be made with a gasket of tarred hemp and caulked with a mixture of neat cement just moist. The pipes shall be secured to the wall with approved holderbats which shall be securely fixed to the wall with rawlbolts.

Ventilating pipes shall be carried at least 900mm above eaves level and shall be fitted with approved coated wire balloon.

Rising Main

The Contractor shall include for all charges for tapping and connection to public water main, including all necessary excavations and reinstatement of public roads.

Galvanised pipes and fittings for water services

All internal and external water services, fittings, wastes, overflows and the like shall be in screwed and socketted galvanized wrought iron or steel tubes and tubulars, the former complying with BS 788 for water (medium) and the latter with BS 1387 for B class. Pipes above ground level shall be fixed to walls with approved type galvanised malleable iron built in clips, brackets, holderbats or pipe clips, the spacing of which shall not exceed 900mm.

The jointing of galvanized piping and fittings shall be made with proprietary brands of jointing paste or compound complying with BS 1260 and if these are not obtainable by a method to be approved by the Architect.

Unless otherwise specified or detailed on drawings the internal diameter of service pipes shall comply with the following:

Diameter of supply or feed pipe	No. of tappings shall not exceed
13mm	2-13mm
19mm	4-13mm
25mm	-13mm or 2 – 19mm
31mm	10-13 mm or 2 – 25mm
38mm	16-13mm or 6 – 19mm
	3 – 25mm or 2 – 31mm

Water taps

All bib, pillar, globe and stop taps shall be of the screw down pattern and comply in every respect with BS 1010. The size specified or shown on the drawing shall mean the maximum bore of the seating.

Stopcocks and boxes

Brass stopcocks shall be provided at the immediate entry of the water services into the building and at the other points as indicated on the drawings and shall be of a pattern approved by the Architect.

Stopcock boxes where required externally shall be constructed of 150mm earthenware pipe out to the required length and fixed vertically over the stopcock on two concrete blocks and the earth well consolidated round the sides. Top of pipe to be fitted with 225mm x 25mm, thick precast concrete cover reinforced with 13mm chicken wirenetting and fitted with a lifting ring.

Testing of water services

The whole of the water services laid or fixed by the contractor shall be tested at the contractor's expense in the presence of the Architect and shall comply with his requirements and any defects made good to his satisfaction. In the absence of instructions regarding the test it shall be an air pump and pressure gauge test the pressure applied at 35 to 53 grms per cm<sup>2</sup> for one hour at the end of which period the loss in pressure shall not be greater than 1/50<sup>th</sup> of lb. per 225 mm<sup>2</sup>.

Waste pipes

Waste from sinks and shower to be in 38mm bore pipe and from lavatory basins to be 31mm. All wastes to be carried through external walls to discharge over gully gratings. All waste pipes shall be at each change of direction of pipe be fitted with a tee, one end with screwed plug for cleaning purposes. The external gully to be connected to the nearest manhole. Wastes from urinals to be taken in 50mm diameter cast iron pipe with trap at urinal end and connected by 50mm pipe externally to the nearest manhole. All laid to fall.

Overflow pipes

Overflow pipes are to be fitted to all w.c distant tanks and baths and in each case the overflow pipe shall be 6mm longer in diameter than the water supply to the unit. Overflow pipes to w.c cisterns shall be taken through an external wall to finish 150mm beyond the face of the wall.

Supply of sanitary ware

Baths, w.cs, basins, sinks and other sanitary units shall be of approved manufacture and shall comply with the relevant B.S.S. They shall be of the type and designs shown on the drawings or to the Architect's instructions. The whole of the units shall be properly fixed and connected to the water service complete with wastes and overflows as described.

Rainwater pipes

Rainwater pipes shall be approved rigid P.V.C rainwater unless otherwise described. Pipes shall be properly fixed to walls with approved clips at distance to be directed by the Architect.

Drain pipes for soil drainage

All pipes for soil drainage which include the conveyance of discharges from wcs, basins, sinks, drains, baths and showers shall salt-glazed earthenware pipes, bends, junctions and tapers complying in all respects with B.S no. 63 for "British Standard

Pipes” and must be stencilled with the registered mark of the B.S.I. Other fittings shall comply with the dimensions laid down in B.S 539. If the above type of pipe is unobtainable then best Commercial Quality may be used on conditions prior approval of the Architect is obtained.

Drain pipes for water drainage

Pipes conveying storm or surface water shall be second quality distinguished by a black band.

Laying of drain pipes

The pipes to be laid in straight runs to even and regular falls, and put together with great care, the spigot of one pipe shall have one lap of tarred gaskin wrapped round it and then placed into the socket of the pipe previously laid. After the adjustment the gaskin shall be caulked lightly home but not so as to occupy more than one quarter of the socket depth. The socket shall then be completely filled with cement mortar (1:1) and a fillet shall be formed round the joint, with a trowel forming an angle of 45 degrees with the barrel of the pipe. The joint inside to be struck with a scraper, so as to give a perfectly clear and unobstructed water way.

Fall in drains

All pipes except where otherwise shown shall be 125mm internal diameter laid to a fall of 1:50.

Concrete bed to drains

Concrete (1:3:6) shall be laid 150mm thick to form bed for drains where the soil is found to be soft. After the pipes have been tested, it shall be haunched up on both sides to a height of 3/4<sup>th</sup> of the internal diameter of the pipe.

Concrete cover to drains

All pipes passing under buildings or under roadways shall, in addition to a 150mm concrete bed under, be completely surrounded in concrete of the same thickness of (1:3:6 mix).

Gully traps

Provide trapped gullies, complete with gratings in positions shown on drawings, set on concrete and surrounded in concrete, and jointed to drain as described.

Manholes

Manholes are to be constructed in the positions shown on the drawings. The internal dimensions of the manholes shall vary according to their depth and shall be as follows:

Depth of manhole from top of invert to finished ground level

Internal dimensions of manhole shall not be less than

Up to 600mm

600 x 450mm

Up to 900 mm

750 x 600mm

Up to 1200 mm

825 x 675mm

Up to 1500mm

900 x 750mm

Exceeding 150mm in depth the Contractor shall apply to the Architect for details.

Manholes shall be constructed in concrete (1:3:6) cast in situ hacked for key and finished above the benching with 6mm thick rendering of cement and sand mixed in the proportions of 1 to 2. The thickness of the concrete walls shall vary according to the depth and shall be as follows:

Depth of manhole from top of invert to finished	thickness of concrete to manhole walls shall not be less than
Up to 600mm deep	100mm thick
Exceeding 600mm but not Exceeding 1500mm	150mm thick

Exceeding 1500mm in depth the Contractor shall apply to the Architect for details.

The floor of manholes shall be 150mm thick and the channels and benching shall be formed above the level of the floor in fine concrete (1:2:4) average 225mm thick with a polished fall and carried up 450mm above invert level and channels. The cement for benching to be sulphate resisting cement. Step irons shall comply with B.S 1247 and shall be placed at intervals of 450mm vertically with 300mm offset between alternate steps.

Manhole covers other than those in roadways shall be 600 x 450mm cast iron medium weight with frame set flush in 125mm concrete cover slab Mix C., the building shall be bedded in grease and shall be of an approved heavy iron pattern and the contractor shall apply to the Architect for details including the construction of the manhole.

Soakaways

Construct soakaways not less than 6m away from the building in position approved by the Architect. Water from rainwater pipes to be first taken into a trapped gulley below rainwater pipes to be first taken into a trapped gulley below rainwater pipes and thence by 100mm diameter pipe to soakaway. The soakaway to be 900mm x 900mm x 1500mm deep filled with stones and finished with a 300mm layer of 38mm macadam.

Cast concrete kerb around gulley and soakaway in mix B concrete 100mm thick and 225mm deep to project 125mm above ground level. Render kerbs with a 1:3 cement and sand and finish with slightly rounded edges.

Septic tank

Septic tanks shall be constructed in position shown on the site plan not less than 15m. away from the building, in accordance with detail drawing.

Intercepting chamber

Intercepting chamber shall be constructed as described for manholes with an approved saltglazed eathernware intercepting trap with rodding arm fitted with standard jointed stopper set and surrounded in concrete mix C and jointed to drain.



Fresh air inlet

Build into the side of the intercepting chamber a 100mm diameter cast iron pipe with bend to terminate not less than 750mm above ground level jointed to an approved 100mm galvanized fresh air inlet valve with cast brass flap and hinged mica flap.

Drain testing

All drainage runs shall be tested before tracks are filled up and afterwards when the drainage system is complete in the presence of the Architect. The contractor shall supply all necessary equipment and labour for carrying out the tests. The air test shall be carried out by plugging all openings with standard air test apparatus to one end. The air pressure in pipes to be built up by means of a suitable pump until a head of 100mm is reached and the test continued until approved by the Architect. The maximum loss allowed shall be a fall of 25mm over a period of 5 minutes after pumping has ceased. If the fall exceeds 25mm a smoke test shall be immediately carried out to locate defects and all such defects shall be made good and further tests carried out at no extra cost to the Employer.

**ROADS AND FOOTPATHS**

Site clearance

All roots, tree stumps, rocks and similar obstructions in the line of The excavation of the road or footpath shall be removed from the site having due regard to Clause No. 1 of the Excavator section of this specification.

Macadam finished roads

Excavate to a depth of 225mm below the required finished level of the road, and to the full width directed. All excavated materials shall be spread and levelled on the site or removed from the site as directed by the Architect.

Tarmacadam roads,  
Drives playground, etc.

Remove top soil to a minimum depth of 225mm and compact formation level by a 8-10 ton roller. Where formation is composed of clayed soil (to be decided by the Architect) apply a layer of coral sand 38mm thick and compact again.

Operation 1

Operation 2

Hardcore filling consisting of angular shapes blue basalt spalls 150mm x 100mm x 75mm type B to be placed on the compacted surface after operation 1, blinded with 63mm aggregate and compacted with the 8-10 ton roller by successive passes until a well interlocked mass is obtained.

Operation 3

Spread 25mm aggregate on the compacted hardcore filling after operation 2 at the rate of 16-18 sq. metre of surface per cu.metre, blinded with 19mm aggregate at the rate of 40-50 sq.metre of surface per cu.metre and compacted with the 8-10 ton roller until no movement of the 19mm aggregate is possible.

Operation 4

Spray bitumen of 6/70 penetration at a temperature of 300°F (using a bitumen sprayer) at the rate of 2 sq.metre per gallon, followed immediately by 9mm aggregate at the rate of 150 sq. metre of surface per cu.metre and rock sand at the rate of 300 sq. metre of surface per cu. metre compact with a 8-10 ton roller after the surface has been smoothed up by hand and brass brooms.

NOTE: The surface to be finished to the level decided by the Architect on site.

Kerbing in stone

Edges of all roads requiring stone edging; the level kerbing shall be made of selected rocks with level and square exposed edges of full thickness of the hardcore and finished flush with the road surface.

Kerbing in concrete

To edges of all playground and paved areas except where otherwise indicated provide 300mm wide and 225mm deep concrete curbs, cast in situ to full widths and depths of 1:2:4 concrete, with smooth trowel finish to exposed edges and finished flush with and to follow falls of paved areas. At inter-sections of curbs and at intervals of 30 metres in straight run provide 13mm wide butt jointed expansion rail to back of kerbs to within 50mm of top of curb and where filled filling to be banked at a slope not exceeding 1 in 3.

**EXCAVATION**

**2.1 Inspection of Site**

The Contractor is deemed to have visited the Site and to have ascertained the nature of the material to be excavated.

**2.2 Dealing with water**

The contractor's attention is drawn to the depths below ground level of the foundations and the consequent possibility of having to deal with water. Unless otherwise specified the contractor will be required by pumping or other means to keep the excavations dry during construction.

**Shoring of existing structure**

The contractor's attention is drawn to the requirements for shoring parts of the structure of the existing building during construction and the consequent need to carry out the excavation in stages. He is not allowed to excavate within the proximity of the existing structure without the drawings and/or instructions by the Engineer to do so.

### 2.3 **Excavation Dimensions:**

The excavation are to be executed to the widths and depths shown on the Drawings or to greater depths if instructed by the Engineer to obtain satisfactory foundations.

If the contractor excavates to any widths or depths greater than those shown on the Drawings, or as instructed by the Engineer he shall at his own expense fill in such widths or depths beyond that instructed or shown with concrete Grade "D" to the satisfaction of the Engineer.

### 2.4 **Rock**

"Rock" means any hard material, which in the opinion of the Engineer can be removed only by use of compressors or by wedging and the Engineer's opinion shall be final. Decomposed rock, tuff or other material which can be removed by pick, traxcavator or other mechanical plant will not be classed as rock. All material classified as rock may, if approved by the Engineer, be used as hardcore filling and the measured quantities of imported filling will be adjusted accordingly. All rock so used must be broken to the required size as hereafter described before being used.

### 2.5 **Blasting:**

No blasting will be permitted.

### 2.6 **Bottom of excavations to receive foundations:**

The Contractor shall report to the engineer when secure bottoms to the excavations have been obtained. Any concrete or other work executed before the excavations have been inspected and approved, shall if so directed, be removed and now work substituted after the excavations have been approved, all at the Contractor's expense. The surface of the bottoms to excavations shall be levelled or graded to falls as required, with 50mm layer of concrete Grade "D" blinding (maximum 20mm gauge aggregate) and finished to a smooth surface with a wood float.

### 2.7 **Hardcore filling:**

Hardcore for filling under float, etc, shall be good hard stone ballast to the approval of the Engineer, broken to pass not greater than a 150mm ring or to be 75% of the finished thickness of the layers being completed whichever is the lesser and graded so that it can be easily and thoroughly compacted by rolling.

The filling is to be laid in layers each of a consolidated thickness not exceeding 225mm and well watered and rolled with a vibrating roller (minimum 14 tons) or a ten ton roller. Where rollings impossible, compaction shall be by hard or mechanical tampers. The top surface of the hardcore shall be levelled or graded to falls as required and blinded with similar material broken to 25mm gauge and surfaced with a 25mm layer of stone dust, well watered and rolled to receive concrete as described.

### 2.8 **Materials found in excavations**

No material found in the excavation is to be used in the works without the written permission of the Engineer.

## **CONCRETE WORK**

### **3.1 Architect/Engineer**

For the purpose of the concrete structure the Structural Engineer shall be deemed invested with the duties and be the representative of the Architect.

### **3.2 Code of Practice**

All workmanship, materials, tests and performance in connection with the reinforced concrete work shall be in conformity with the latest edition of the British Standard Code of Practice (C.P. 110 "The Structural use of Concrete") where not inconsistent with these Preambles.

### **3.3 Supervision**

A competent person approved by the Engineer shall be employed by the Contractor whose duty will be to supervise all excavation operations, making and erection of formwork, sending and fixing of reinforcement and all stages in the preparation and placing of the concrete. All cubes shall be made and side test carried out under his direct supervision, in consultation with the Engineer.

### **3.4 Contractor's plant equipment and construction procedures:**

Not less than 30 days prior to the installation of the contractor's plant and equipment for processing, handling, transporting, storing and proportioning ingredients and for mixing, transporting and placing of concrete, the contractor shall submit drawings for approval by the Engineer, showing the proposed general plant arrangement, together with a general description of the equipment he proposes to use.

After completion of the installations, the operation of the plant and equipment shall be subject to the approval of the Engineer.

Where these Preambles, the Bills of Quantities or the Drawings require specific procedures to be followed, such requirements are not to be construed as prohibiting the use by the Contractor of alternative procedures if it can be demonstrated to the satisfaction of Engineer, that equal results will be obtained by the use of such alternatives.

Approval of plant and equipment or their operation, or of any construction procedure, shall not operate to waive or modify any provisions or requirements contained in these preambles governing the quality of the materials or of the finished work.

### **3.5 Levels and Foundations:**

The foundations of the works shall be carried down to depths as may be directed by the Engineer and they must be cut as nearly to the size of the concrete as possible and the vacant spaces between the concrete and the solid ground, excepting where otherwise shown, must be carefully filled in as instructed by the Engineer.

All temporary timbering shall be removed but should any timber be left in or should any other work be done beyond that specified, it will be at the Contractor's own cost.

### 3.6 **Tolerances:**

On all setting out dimensions of 7.5m and over a maximum non-cumulative tolerance of plus or 6mm will be allowed, and for those under 6m the allowable maximum non-cumulative tolerance will be plus or minus 3mm. On the cross sectional dimensions of structural members, unless otherwise required by the Drawings, a maximum tolerance of plus or minus 3mm will be permitted.

The top surface of concrete floor slabs and beams shall be within 6mm of the normal level and line shown on the Drawings. Walls and columns shall be truly plumb and non-cumulative tolerance of 3mm in each storey and not more than 12mm out of plumb in their full height will be permitted. The contractor shall be responsible for the cost of all corrective measures required by the Engineer to rectify work which is not constructed within the tolerances set out above.

### 3.7 **Materials generally:**

All materials which have been damaged, contaminated or have deteriorated or do not comply in any way with the requirements of these Preambles shall be rejected and shall be removed immediately from the site at the Contractor's own expense.

No materials shall be stored or stacked on suspended floors without the Engineer's prior approval.

### 3.8 **Samples and Testing:**

Every facility shall be provided to enable the Engineer to obtain samples and carry out tests on the materials and construction. If these tests show that any of the materials or construction do not comply with the requirements of these Preambles, the Contractor will be responsible for the costs of the tests and the replacement of defective materials and/or construction.

### 3.9 **Cement:**

Cement unless otherwise specified shall be Portland Cement of a Brand approved by the Engineer and shall comply with the requirements of B.S. 12, and a manufacturer's certificate of Test in accordance with B.S. 12 shall be supplied for each consignment delivered to the site.

Cement may be delivered to the site either in bags or in bulk.

If delivered in bags each bag shall be properly sealed and marked with the manufacturer's name and shall be stored in a weatherproof shed of adequate dimensions with a raised floor. Each consignment shall be kept separate and marked so that it may be used in the sequence in which it is received. Any bag found to contain cement which has set or partly set. shall be completely discarded and not used in the works. Bags shall not be stacked more than 1.5m in height.

If delivered in bulk the cement shall be stored in a waterproof site either provided by the cement supplier or by the contractor but in either case the site shall be to the approval of the Engineer.

### 3.10 **Aggregates:**

Aggregates shall conform with the requirements of B.S. 882 and the sources and types of all aggregates are to be approved in all respects by the Engineer before work commences.

The grading of aggregates shall be one within the limits set out in B.S. 882 and as later specified and the grading, once approved, shall be adhered to throughout the works and not varied without the approval of the Engineer. Fine aggregate shall be clean, crushed rock sand and coral sand, of hard quality and shall be free from lumps of stone, earth, loam, dust, salt, organic matter and any other deleterious substances. Coral sand shall be washed in running water to the satisfaction of the Engineer. It shall be graded within the limits of zone 1 or 2 of table 2 of B.S 882.

Coarse aggregate for concrete Grade 'A', 'B' and 'C' shall be crushed blue basalt stones to the approval of the Engineer. It shall be hard, clean and roughly cubical in shape, non porous, free from dust, decomposed stone, clay, earthy matter, foreign substances or friable, thin, elongated or laminated pieces. It shall be graded within the limits of Table 1 of B.S. 882 for its respective nominal size. If in the opinion of the Engineer the aggregate meets with the above requirements but is dirty or adulterated in any manner it shall be screened and/or washed with clean water, if he so instructs at the Contractor's expense.

Aggregates shall be delivered to the site in their prescribed sizes or gradings and shall be stock-piled separately on paved areas or boarded platforms in separate units to avoid intermixing, excessive segregation and contamination with other materials. On no account shall aggregates be stock-piled on the ground. Fine aggregates shall be allowed to drain until it has reached a uniform moisture content before it is used.

### 3.11 Water

The water used for mixing concrete shall be from an approved source, clean, fresh and free from harmful matter.

### 3.12 Admixtures;

No admixtures except the ones specified for waterproof concrete shall be allowed. The Contractor may use an approved "plasticizer" which will be added to the mixing water in the proportion recommended by the manufacturer and strictly in accordance with their written instructions, to achieve better workability. No additional cost will be paid for the use of the plasticiser.

## CONCRETE STRENGTHS

### 4.1 Grades of Concrete:

Grades 'A', 'B' and 'C' concrete shall have the following minimum strengths as given by Works Cube Test:

	<u>Grade A</u>	<u>Grade B</u>	<u>Grade C</u>
Min. crushing) at 7 days	21	17	14
strength in ) at 28 days	30	25	20
N/mm )			

Grade 'D' and 'E' concrete shall be of the following nominal mixes and may be moistured either by volume or by weight. No cube tests will be required for Grades 'D' and 'E' concrete. These grades will be used for un reinforced concrete, with a minimum slump of 50mm.

<b><u>Grade</u></b>	<b><u>D</u></b>	<b><u>E</u></b>
Nominal mix by	1.10	1.10 (with plums not exceeding 20% by total volume of concrete)
Max. gauge of coarse aggregate (* or 20mm for blinding concrete where described).	40mm*	40mm*

#### 4.2 **Maturing of Concrete Materials** **Cement**

The quantity of cement shall be measured by weight. Where delivered in bags, each batch of concrete is to use one or more whole bags of cement.

#### **Aggregate**

- (i) For Grades 'A', 'B' and 'C' concrete, aggregates may be measured by weight in weigh batching machine as described hereafter.
- (ii) For Grades 'D' and 'E' concrete, aggregates shall be measured by weight or by volume. Where measured by volume, approved gauge boxes of such a size as will give the correct proportions shall be used.

#### 4.3 **Weigh batching machine**

Weigh batching machine shall be of an approved type and shall be properly maintained and checked for accuracy at weekly intervals.

#### 4.4 **Concrete Mixes 'A', 'B' and 'C'**

As specified above.

The Contractor shall have two alternatives to achieve the specified concrete strengths.

#### 4.5 **Alternative 1 Design Mix**

Contractor can use minimum amount of cement by weight per cubic metre of finished concrete as set out below, if he provides strict with CP 110 Clause 6.5. Requirements for design mixer.

Target mean strength. Evidence of suitability of proper mix proportions.

Trial mixes.

#### 4.5.4 Additional Trial Mixes

The copies of this circular is available from the Engineer 's office on request by the contractor.

The minimum cement content by weight shall be

Minimum cement content  
per cubic metre of  
finished concrete

450 kg          360 kg          250 kg

#### 4.6 Alternative 2

If the contractor fails to receive the requirements of alternative 1 and/or prefers nominal volumetric mix, he shall use the following:

	<u>Mix A</u> 1:13/16:2	<u>Mix B</u> 1:1 ¾:3	<u>Mix C</u> 1:2 ½:4
Cement	1 bag of 50 kg	1 bag of 50 kg	1 bag of 50 kg
Crushed rock sand	1 cu. ft	1¼ cu.ft	1 7//5 cu.ft
Coral sand 10mm to 5mm	½ cu. ft	7/8 cu.ft	14 cu.ft
Graded aggregates 20mm to 10mm	5/8 cu.ft	7/8 cu.ft	1¼ cu. ft
Graded aggregates	1 7/8 cu.ft	3 cu. ft	3 ¾ cu ft
Maximum water			
Cement ratio	5	.56	.60
Maximum slump	50mm	50mm	50mm

Average works strength obtained from work care of nominal volumating mixes shall be 10% higher than the minimum concrete strengths specified.

#### 4.7 Ready Mix Concrete

Ready mixed concrete may be used subjects to the approval of the Engineer.

When it is used the contractor shall ensure that all the requirements of these specifications are complied with. The Engineer may at his discretion waive temporarily the requirements of preliminary trial mixes as required under the heading of trial mixes laid down for alternatives design mix.



Further to requirements the contractor shall ensure that supply and delivery of ready mixes concrete comply with the recommendations of M.S. 1926.

The concrete shall be transported to the site in approved containers and shall be continuously agitated until it is delivered on site. The Contractor shall ensure that no water is added after it is delivered.

For plant mixed concrete the contractor shall check that the delivery note for each batch shows the time when water is first added to the concrete materials, and the time interval between the delivery and the mixing of water is 20 minutes less than the final setting time of cement.

Samples of workcube shall be taken at the place where concrete is finally placed in the structural members.

#### **4.8 Waterproof Concrete**

Where “waterproof concrete” is specified, sealocrete or other approved waterproofing material and plasticizing agent shall be added to the mixing water in the proportion recommended by the manufacturers and strictly in accordance their written instructions. Waterproof concrete shall be grade B mix and shall meet all the strength requirements of the specified grade, except that the fine aggregate shall consist solely of rock sand.

#### **4.9 Changing proportion of Aggregates**

The Engineer may any time during the contract, require the proportions of fine to coarse aggregates to be altered in order to produce a mix of greater strength or improved workability and provided that the total proportions of aggregate to cement remains unchanged, no claim for additional cost will be considered.

#### **4.10 Testing Equipment**

The Contractor shall provide the following equipment for carrying out control tests on the site:

- a) Straight edges 3m and 1.2m long for testing the accuracy of the finished concrete;
- b) A graduated glass cylinder for use in the silt test for organic impurities in the sand;
- c) Slump test apparatus;
- d) Six inch steel cube moulds with base plates and tamping rods to B.S. 1881.

#### **4.11 Work Cube Tests**

Work cubes are to be made at intervals as required by the Engineer and the Contractor shall provide a continuous record of the concrete work. The cubes shall be made in approved 150mm moulds in strict accordance with the Code of Practice.

Six cubes shall be made on each occasion, three from different batches, of the concrete at the place where it is deposited.

Each cubes shall be made on each occasion, three from different batches, of the concrete at the place where it is deposited.

Each cube shall be marked with a distinguishing number (numbers to run consecutively) and the code on which it is made. A record shall be kept on site giving the following partitioning.

- (a) Cube No.
- (b) Date Made
- (c) Location in
  
- (d) 7-day Test  
  
Date  
Strength
  
- (e) 28-day Test  
  
Date  
Strength

Cubes shall be forwarded by the Contractor to an approved Testing Authority, in time to be tested two at 7 days and two at 28 days. The remaining two cubes shall be tested when necessary.

Copies of all work cube Test results shall be forwarded to the Engineer and one shall be retained on the site.

If the prescribed concrete strengths are not attained and maintained throughout the carrying out of the contract, the Contractor will be required to increase the proportion of cement and/or substitute better aggregates so as to give concrete which does comply with the requirements of the contract. The Contractor may be required to remove and replace at his own cost any concrete which fails to attain the required strength as ascertained by Work Cube Tests.

The Contractor must allow in his rates for all expenses in connection with the preparation, conveyance to the Testing Laboratory, and testing of cubes.

### **CONSTRUCTION JOINTS**

#### **5.1 Position of Construction Joints:**

Construction joints shall be permitted only at the locations shown on the Drawings or as instructed on the site by the Engineer. In general they shall be perpendicular to the lines of Principal and shall be located at points of minimum shear, viz vertically at, or near, mid-span or slabs and beams.

#### **5.2 Maximum distance between Construction Joints**

Suspended slabs are generally to be cast using alternative bays not exceeding 12m in length. At least 40 hours shall elapse between the adjacent bays/shall be in positions to be agreed with the Engineer.

Beams shall be cast with the slab. Mass concrete shall be cast in alternate bays in lengths not exceeding 7.5m and in depths not exceeding 1.5m. Adjacent sections shall not be cast within 48 hours of each other.

Under no circumstances shall concrete be allowed to fail off but shall be deposited against stopping-boards.

### 5.3 **Preparation of Construction Joints**

Before placing new concrete against concrete already set, the face of the old concrete shall be thoroughly backed, roughened and cleaned, and laitance and loose material removed therefrom. Immediately before placing the new concrete the surface shall be saturated with water. A layer of mortar not less than 25mm in thickness and consisting of 1 part of cement to 1½ parts of fine aggregate shall be applied to the face of the old concrete. All exposed construction joints shall be treated with epoxy resin in accordance with the manufacturer's instructions.

## **EXPANSION/CONTRACTION JOINT**

Joints fillers and sealants shall be of an approved type unless shown on the drawings. Reinforcement or other embedded items bonded to the concrete shall not extend continuously through any expansion/construction joint.

## **WATERBARS**

### 7.1 **Type**

Waterbars shall be P.V.C waterbars of an approved type and shall be provided in the positions indicated on the drawings.

### 7.2 **Joints**

Joints shall be heat welded in accordance with the manufacturer's instructions and where the waterbar is to be fixed vertically, metal clips as manufactured by the supplier of the waterbar or of other approved design shall be provided to suspend the waterbar from the reinforcement.

### 7.3 **Additional Water Bar**

Where waterproof concrete is used the Contractor shall adhere strictly to the position and type of construction joints as detailed on the Drawings. Any deviation from this procedure or the provision of additional construction joints will require the prior approval of the Engineer and any additional waterbars which may be required will be at the Contractor's expense.

### 7.4 **Formwork to Water Bars**

Formwork shall be designed with sufficient timber formers and blocking pieces to support the waterbar and to ensure that it is not displaced during concreting. In the case of horizontal joints in vertical walling and similar members of the formwork shall be so constructed as to permit the starter or upstand of concrete surrounding the lower half of the waterbar to be poured in the same operation as the slab

or other member from which it springs. Formwork to walls or similar members where a water bar is positioned at the bags of the lift shall have sufficient openings not less than 300mm square at approximately 225mm above the level of the waterbar to permit checking that the waterbar is correctly positioned and not displaced during concreting.

No concreting will be permitted to portions where upstand startup from an integral part until the formwork to the starter has been fixed and approved.

### **CONCRETE**

All sleeves, inputs, anchors and embedded items required for adjoining work or for its support shall be approved by the Engineer and shall be placed prior to concreting and shall be used after an interval of time approved by the Engineer.

All contractors whose work is related to the concrete or must be supported by it shall be given ample time and opportunity to furnish embedded items before concrete is placed.

Expansion joint material, waterstops, and other embedded items shall be positioned accurately and rigidly. Voids in sleeves etc. shall be filled temporarily with readily removable material to prevent concrete entering into them.

### **PLACING CONCRETE**

#### **Concrete Mixer:**

The concrete shall be mixed only in approved power driven mixers of a type and capacity suitable for the work. Mixers shall be of a capacity sufficient to take one whole bag of cement per batch. Smaller size mixers shall not be used. The mixer shall be equipped with an accurate water measuring device which shall be checked weekly for accuracy. All materials shall be thoroughly mixed dry before the water is added and the mixing of each batch shall continue for a period of not less than two minutes after the water has been added and until there is a uniform distribution of the materials and the mass is uniform in colour.

The entire contents of the mixed drum shall be discharged before recharging. The volume of mixed materials shall not exceed the rated capacity of the mixer. Whenever the mixer is started, 10% extra cement shall be added to the first batch and no extra payment will be made on this account.

#### **Consistency:**

As a check on concrete consistency slump tests may be carried out and shall be in accordance with B.S 1881. The Contractor shall provide the necessary apparatus and allow for the costs of such tests. The slump of the concrete made with the specified water content, using dry materials, shall be determined and the water to be added under wet conditions shall be so reduced as to give approximately the same slump.

**Conveying:**

The concrete shall be mixed as near to the place where it is required as is practicable to avoid rehandling and flowing, and only as much as be required for a specified section of the work shall be mixed at one time, such section being concerned and finished is one operation without delay. All concrete must be efficiently skilled and used in the works within twenty (20) minutes of mixing. It shall be discharged from the mixer direct either into receptacles or barrows and shall be distributed by approved means which do not cause segregation or loss of ingredients or otherwise repair the quality of the concrete. Approved mechanical means of handling will be provided they are not longer than 6m and their slope do not exceed 1 vertical to 2 horizontal is not less than 1 vertical to 3 horizontal.

**Depositing**

Placing of concrete in supported elements e.g slab, bed shall not be started until the concrete previously placed in top parts of columns is no longer plastic and has been in place at least for two hours.

Concrete shall be placed from a height not exceeding 1.3m directly into its permanent position and shall not be worked along the shutters to that position. Unless otherwise approved, concrete shall be placed in a single operation to the full thickness of slabs with beams and similar members. The Engineer shall allow concrete to be placed for walls exceeding 150mm thickness from a height approved system of formwork is used.

In addition contractor will ensure that the concrete shall be deposited continuously such that no concrete shall be deposited on concrete which had hardened sufficiently to cause the formation of seams or places of weakness within the section. Placing shall be carried out at such a rate that the concrete which is being integrated with fresh concrete is still plastic.

Concrete in columns may be placed in a height of 3m with careful placing and vibration to achieve satisfactory results. Where the height of the column exceeds 3m suitable openings must be left in the shutters on that this maximum lift is not exceeded.

Concrete shall be placed continuously until completion of the part of the work between construction joints as specified hereinafter or of a part of approved extent. At the completion of a specified or approved part a construction joint of the form and in the positions hereinafter specified shall be made. A record of all such joints must be made by the contractor and a copy supplied to the Engineer.

**Placing concrete under water**

When required concrete shall be deposited under water by an approved method in such a way that the fresh concrete enters the mass of previously placed concrete from within, causing water to be displaced with minimum disturbance at the surface of the concrete.

**Precautions of mixing and placing:**

Any accumulation of set concrete on the reinforcement shall be removed by wire brushing before further concrete is placed. The contractor shall provide runways for concreting to the satisfaction of the Engineer. Under no circumstances will the runways be allowed to rest on the reinforcement.

Care shall be taken that the concrete is not disturbed or subjected to vibrations and shocks during the setting period.

Mixing machines, platforms and barrows shall be cleaned before commencing mixing and be cleaned on every cessation of work.

Where concrete is laid on hardcore, concrete blocks or other absorbent materials, the base shall be suitably and sufficiently wetted before the concrete is deposited.

### **Compaction**

#### **Compaction:**

At all times during which concrete is being placed, the contractor shall provide adequate trained and experienced labour to ensure that the concrete is compacted in the forms to the satisfaction of the Engineer.

#### **Depth of Compaction:**

Concrete shall be placed neither at a rate greater that will permit satisfactory compaction nor to a depth greater than 750m before it is completed.

#### **Vibration of Concrete:**

During and immediately after placing, the concrete shall be thoroughly compacted by means of continuous tamping, spading, slicing rodding, forking and vibration. Vibration is required for all concrete of grades 'A', 'B' and 'C'.

Care shall be taken to fill every part of the forms, to work the concrete under and ground the reinforcement without displacing it and to avoid disturbing recently placed concrete which has begun to set.

Any water accumulating on the surface of newly placed concrete shall be removed and no further concrete shall be placed thereon until such water be removed.

#### **Internal Vibrators:**

Internal vibrators shall have a frequency of not less than 7,000 cycles per minute and shall have a rotating eccentric weight of at least 2 kg. With an eccentricity of not more than 12mm. Such vibrators shall visibly affect the concrete within a radius of 22mm from the vibrator.

Vibrators shall not be used to move concrete from place to place in the formwork.

At least one internal vibrator shall be operated for every two cubic metres of concrete placed per hour and at least the spare vibrator shall be maintained on site in case of break-down during concreting operations.

### **External Vibrators**

External formwork vibrators shall be of the high frequency less amplitude type applied with the principal direction of vibration in the horizontal plane. They shall be attached directly in the forms at not more than 1.2m centers.

In addition to internal and external vibration the upper surface of suspended floor slabs shall be levelled with a tamping vibrating speed prior to finishing. Vibrating elements shall be of the low frequency high amplitude type operation at speed of not less than 3,000 r.p.m.

### **Curing and Protection**

#### **Periods and means of curing and protection:**

Care must be taken that no concrete is allowed to become prematurely dry and the fresh concrete must be carefully protected within two hours of placing from rain, sun and wind by means of massive sacking, polythene sheeting, or other approved means. The protective layer and the concrete itself must be kept continuously wet for at least seven days after the concrete has been placed. The Contractor must allow for the complete covering of all fresh concrete for a period of 7 days. Hessian or polythene sheeting shall be in the maximum widths obtainable and shall be secured against wind. The Contractor will not be permitted to use old cement bags, hessian or other material in small piece.

#### **Protection of foundation concrete**

Concrete in foundations and other underground work shall be protected from admixture with falling earth curing and after placing.

#### **Executive loads before curing**

Traffic or loading shall not be allowed on the concrete except with the written permission of the engineer.

### **Faulty Concrete**

Any concrete which fails to comply with these preambles or which shows signs of setting before it is placed shall be taken out and removed from the site. Where concrete is found to be defective after it was set, the concrete shall be out and replaced in accordance with the Engineer's instructions. On no account shall any faulty, honeycombed, or otherwise defective concrete be repaired or matched until the Engineer has made an inspection and issued instructions for the repair. The whole of the cost whatsoever, which may be occasioned by the need to remove faulty concrete shall be borne by the contractor.

### **Reinforcements**

#### **Type of Reinforcement:**

The steel reinforcement shall comply with the latest requirement of the following British Standards:

Round mild, medium tensile and to B.S 765 (Imperial units) high tensile and steel bars.

Hot rolled bars for the reinforcement of concrete	to B.S 1449 (metric units)
Cold twisted steel bars	to B.S 1144 (imported units)
Cold worked steel for the reinforcement of concrete	to B.S 4461 (metric units)
Fabric reinforcement	to B.S 1221

It shall be in Imperial or Metric sizes as detailed on the drawings.

### **Testing of Reinforcement**

If required by the Engineer the contractor shall submit a test certificate of the rollings, and/or shall arrange for testing by MOW or other approved authority. Reinforcement shall be free from loose mill scale or rust, grease, paint or other substance likely to reduce the bond between the steel and concrete.

### **Fabric Reinforcement**

It shall be of size and/or weight specified and shall be tied with other reinforcements with minimum 225mm laps, using no. 19 S.W.C annealed binding wire.

### **Fixing and Reinforcement:**

Reinforcement shall be accurately bent to the shapes and dimensions shown on the Drawings and/or schedule and in accordance with B.S. 1478. Reinforcement must be cut and bent solid and no welded joints will be permitted unless so detailed. Reinforcement shall be accurately placed in position as shown on the drawings and shall be secured against displacement by using No. 18 S.W.C annealed binding wire or suitable clips at inter-sections and laps, and shall be supported by concrete or metal supports, steel chairs, spacers or metal hangers to ensure the correct position and cover before concreting and shall be kept in the same position during concreting. However such supports, chairs etc. shall have minimum 12mm cover made of concrete blocks where the concrete surface is exposed to weather and/or without finishes.

No laps shall be permitted except the laps shown on the drawings without the prior approval of the engineer.

### **Spacing Blocks:**

Spacing blocks of approved size and shape made of concrete similar to that used in the surrounding construction and fixed to the reinforcement or formwork by No. 18 S.W.C wires set into the spacer blocks or other approved means shall be provided where necessary to ensure that the requisite cover is obtained. The contractor is to include for providing sufficient such spacer blocks in his prices for steel reinforcement when such supplier has been nominated.



Where composite blocks or minor forms from construction are just spare block are to be provided. These will generally consist of concrete blocks as described above made to fit the width of the rib less 3 mm of reinforcement bars used per on the top surface with wire ties at each

**Concrete cover to reinforcement:**

Unless otherwise instructed the concrete cover to rod reinforcement over main bars in any face shall be:

Foundations against each face	3 (75mm)
Foundations against blinding	2 (50mm)
Columns	1½ (38mm)
Beams	1 (25mm)
Slabs	½ (13mm)

**Positions and correctness of reinforcement:**

No concreting shall be commenced until the engineer has inspected the reinforcement in position and until he has approved the same. The contractor shall give two clear days notice of his intention to concrete.

Irrespective of whether any inspection and/or approval of the fixing of the reinforcement has been carried out as above, it shall be the contractor's sole responsibility to ensure that the reinforcement complies with the details on the drawings or schedule and is fixed exactly in the positions shown therein and in the positions to give the prescribed cover.

The contractor will be held entirely responsible for any failing or defect in any portion of the reinforced concrete structure and including any consequent claims, third party claims, etc, where it is shown that the reinforcement has been incorrectly positioned or is incorrect in size or quantity with respect to the detailed Drawings or schedules. Unless permitted by the Engineer, reinforcement shall not be after being embedded in hardened concrete.

**Protection of exposed reinforcement**

Where reinforcement projects frame concrete setting of the structure and this reinforcement is executed to remain exposed to more than a month it is to be with a cement to prevent rust staining on the finished concrete. This is to be brushed off the reinforcement prior to the continuation to converting.

The Contractor shall be responsible for the co-ordination with the Electrical and other sub-contractors for incorporating electrical conduit, pipes, fixing locks, chases, holes and the like in concrete members as required and must ensure that adequate notice is given to sub-contractors informing them when concrete members incorporating the above are to be poured. The contractor shall submit full details including position of these items to the Engineer for approval before the work is put in hand. All fixing blocks, chases, holes, etc, to be left in the concrete shall be accurately set out and cast with the concrete.

### **Position of electrical conduit**

Unless otherwise instructed by the Engineer a electrical conduit to be positioned within the reinforced concrete shall be fixed inside the steel cages of beams and columns and between the top and bottom steel layers in slabs and similar members. No conduits are to be placed into concrete members having a dimension less than 100mm.

The proposed position of all electrical conduits 25mm and over in diameter which are to be enclosed in the concrete shall be shown accurately on a plan to be submitted to the Engineer, whose approval shall be obtained before any such conduit is placed.

### **Formwork**

#### **Materials and Design**

Formwork shall be constructed of timber or steel or precast concrete or other approved material with sufficient strength to withstand pressure resulting from placing and vibration of the concrete and with rigidity to achieve the specified tolerances.

The design and Engineering of the formwork as well as its construction shall be the responsibility of the contractor. The Formwork shall be designed for the loads, lateral pressure, pressure due to cyclonic winds and other loads likely to be encountered on site.

Shops drawings for formwork including the location and reshoring shall be submitted for approval by the Engineer before erection.

#### **Construction**

All formwork shall have joints close enough to prevent leakage of liquid from the concrete and formwork shall be jacked or dedged and clamped or bolted to permit adjustments before concreting and to permit easing and removal of formwork without jarring the concrete. Formwork shall be securely braced and strutted against lateral deflections and vertical movements. Where formwork is supported on previously constructed portions of the reinforced concrete structural frame, the Contractor shall by consultation with the Engineer ensure that the supporting concrete structure is capable of carrying the load and/or is sufficiently propped from lower floors or portions of the frame to permit the load to be temporarily carried during construction.

Formwork shall be cambered to compensate for anticipated deflections prior to hardening of the concrete.

#### **Preparation for Concreting**

The Contractor's attention is drawn to the various surfaces textures and applied finishes required and the faces of the formwork next to the concrete must be of such material and construction and be sufficiently true to provide a concrete surface which will in each particular case permit the specified surface treatment or applied finish.

At construction points contact surface of the form squeating for flush surfaces shall overlap 300mm and shall hold right against the hardened concrete to prevent effects or loss of mortar.

Methods of fixing and positioning of the formwork which results in holes through the concrete and/or left in metal ties or similar in the concrete shall require Engineer's approval.

All surfaces which will be in contact with concrete shall be piled or greased to prevent adhesion of mortar. Oil or grease shall be of a non-staining mineral type applied as a thin film before the reinforcement is placed. Surplus moisture shall be removed from the forms prior to placing of the concrete.

Temporary openings shall be provided at the base of columns, wall and seam forms and at any other points where necessary to facilitate cleaning, and inspection immediately before the pouring of concrete. Before the concrete is placed the shuttering shall be trued-up, and the interior of the form shall be completely cleared of all extraneous materials including accumulated water.

The reinforcement shall then be inspected for accuracy of fixing, immediately before placing the concrete the formwork shall be well wetted and inspection openings shall be closed.

**Defective Formwork:**

Defective formwork shall be removed or strengthened and improved by the contractor according to the instructions by the Engineer.

**Formwork to Construction Joints etc.**

Formwork forming the construction joints and expansion joint shall be rigid, tight to avoid loss of mortar and true in square.

Formwork shall be inspected and passed by the Engineer before placing reinforcement and concreting.

**Stripping Formwork:**

Formwork shall be removed without undue vibration or shock and without damage to the concrete. No formwork shall be removed without the prior consent of the Engineer and the minimum periods that shall elapse between the placing of the concrete and the striking of the formwork will be as follows:

Beam side walls and columns (unloaded)	2 days
Slab soffits (with props designed to left under)	7 days
Beam soffits (with props designed to left under)	10 days

Subject to work cubes achieving the specified strengths and the loads due to construction on them being lighter than the designed loads. The props can be removed for:

Slab .....	10 days
Beams .....	21 days

If the Contractor wishes to take advantage of the shorter stripping times as permitted above for beam and slab soffits when props are left in place, he must so design his formwork that sufficient props as agreed with the Engineer can remain in their original position without being moved in any way until expiry of the minimum time for removal of props. Stripping and re-propping will not be permitted.

Contractor shall be responsible for consequent damage arising from early stripping of form work.

### **Making good:**

After removal of formwork all projections, etc, on the concrete surface shall be chipped off, and made good to the requirements of the Engineer. Any voids or honeycombing shall be treated as described in "faulty concrete".

### **Fair-face etc.**

Where fair-face is specified the contractor shall make a sample of area formed by sides not less than 1.2m for approval by the Engineer and the Architect. Same will apply to Board Marked. Tamped and finishes.

### **Related Uniformed Surfaces**

Top of walls or buttresses, horizontal offsets and similar unformed surfaces occurring immediately adjacent to formed surfaced shall be struck smooth after the concrete is placed and shall be floated to a texture reasonably insistent with that of the formed surfaces.

## **PRECAST CONCRETE**

### **General Requirements**

Unless otherwise approved by the Engineer, all precast concrete construction shall be carried out on the site and shall conform to requirements given elsewhere in these preambles.

The maximum size of coarse aggregate in precast concrete shall not exceed 20mm except for thickness less than 75mm where it shall not exceed 12mm.

The compacting of precast concrete shall conform with requirements given elsewhere in these preambles except for thin slabs where use of immersion type vibration is not practicable. The concrete in those slabs may be consolidated on a vibrating table or by any other methods approved by the Engineer.

### **Steam Curing**

Steam curing of precast concrete will be permitted. The procedure for steam curing shall be subject to the approval of the Engineer.

The precast work shall be made under cover and shall remain under the same cover and shall remain under the same for seven days. During this period and for a further seven days the concrete shall be shielded by sacking or other approved material kept constantly wet. It shall then be stacked in the

open for at least a further seven days to season before being set in position. Where steam curing is used these times may be reduced subject to the approval of the Engineer.

**Method of Handling:**

Precast concrete units shall be constructed in individual forms. The method of handling the precast concrete units after casting, during curing and during transport and erection shall be subject to the approval of the Engineer, providing that such approval shall not relieve the Contractor of responsibility for damage to precast concrete units resulting from careless handling.

**Repairs:**

Repair of damage to the precast concrete units, except for minor abrasions of the edges which will not impair the installation and/or appearance of the units will not be permitted and the damaged units shall be replaced by the Contractor at his own expense.

**Moulds**

Except where precast work is described as “fair-face” the moulds are to be made of metal or are to have metal or plywood linings or are to be other approved moulds which will produce a smooth dense fair face to the finished concrete suitable to receive a painted finish direct and free from all shuttered marks, holes, pinnacles, etc. In his prices for such precast work the Contractor shall include for all rubbing down to produce the finish required to the satisfaction and approval of the Engineer and the Architect.

Where precast work is to have an exposed aggregate as finish the moulds shall be constructed to the requirements given for moulds for “fair face” work. The method of achieving the exposed aggregate finish shall be the aggregate transfer or other approved methods. A sample showing the required finish and shape shall be approved by the Architect/Engineer.

The precast units shall be installed to the lines, grades and dimensions shown on the Drawings or as directed by the Engineer.

**COMPOSITE FLOOR SLABS**

**Size, type and concrete mix for floor block:**

Concrete hollow blocks for use in the composite floor slabs are to be size and shape as shown on the Drawings with 25mm wall thickness and are to be of adequate strength to support the concrete during placing and consolidation by vibration. Blocks are to be manufactured in accordance with the procedure specified in B.S 2028 and to be of a mix not weaker than 1:10 cement: combined aggregates using maximum 10mm size aggregate. No coral sand shall be used in making of concrete blocks.

Concrete blocks are to be cured for at least 28 days before use of the site. During the first seven days of curing, blocks are to be kept permanently damp and protected from exposure to sun and wind.

Concrete blocks are to be well wetted before the pouring of concrete.

### **Composite Floor Construction**

The hollow block floor construction is generally to be as shown on the Engineer's Drawings.

Care shall be taken in placing blocks to ensure that they are set out in accordance with the details shown on the Drawings and that they run truly in line without encroaching on the width of the in-situ ribs.

The open ends of hollow blocks adjacent to the concrete to be placed in-situ are to be plugged or stopped previously with mortar or concrete to prevent the concrete from flowing into the void and the contractor is to include for this in his prices.

The Contractor should note that slip tiles are not to be used to the soffit of ribs and he is to take this into consideration in pricing the items of formwork to the soffit of hollow block floor construction.

Before concreting is carried out the blocks are to be thoroughly wetted.

Care should be taken during concreting that the width of ribs between the rows of blocks and of the solid in-situ concrete shown on the Drawings adjacent to supporting beams is not encroached upon by the blocks. It is essential that the concrete topping be poured at the same time as the ribs between hollow blocks.

### **Fixing of rib reinforcement**

Reinforcement shall be positioned accurately with required cover in accordance with the Drawings and using the particular spacing blocks with wire ties as previously described. Spacer blocks shall be provided in ribs at not more than 1.2m centres. Care must be taken during concreting that the reinforcement is not displaced.

Where holes for services, etc. occur, the necessary holes or pockets shall be accommodated by the replacing of a hollow block by in-situ concrete or the widening of a rib all in accordance with the Engineer's instructions. Prices for holes, etc. through hollow block construction are to include the re-arrangement or substitution of the hollow block with solid concrete in addition to the actual formation of the hole.

### **NOTES CONCERNING MEASUREMENT AND PRICING**

The Contractor must allow for all costs incurred during the progress of the Contract for complying with the provisions concerning the preparation and use graded mixes.

Prices for concrete shall include for mixing and depositing as described or indicated and for hoisting and depositing at the various levels required throughout the building, and shall also include for forming or hacking a satisfactory key for all faces receiving asphalt and plaster work. Prices for slabs shall also include for levelling off the surface as described under "compaction", and all temporary formwork to form construction joints at bay edges.

Prices for reinforced concrete shall, in addition, include for filling into, between or on formwork and thoroughly compacting between and around rods or fabric reinforcement and for forming all additional

construction joints between varying mixes. Where described as vibrated, prices must include for fully vibrating as described.

Formwork (use and waste only is measured net to the actual surface of the concrete to be supported and the prices for formwork shall include for extra material at joints, extra labour and waste for narrow widths, small quantities, overlaps, passings at angles, straight cutting and waste, splayed edges, notchings, etc and for fixing at the various levels including battons, struts and supports and for bolting, jacking, wedging, easing striking and removal. Prices for linear items such as boxings shall include for angles and ends. Strutting has been measured at varying levels to slab soffits only and prices for other items must include for strutting at any level.

Prices for steel rod reinforcement shall include for cutting to lengths and all labour in bending and cranking, forming hooked ends, handling, hoisting and fixing in position and for providing all necessary tying wire and supports. Prices for fabric reinforcement shall include for all straight cutting and waste, handling, hoisting and fixing in position, providing all necessary tying wire, and supports and all extra material in laps.

**INDEX**

1. **GENERAL**

- 1.1 Scope
- 1.2 Definitions
- 1.3 Responsibility

2. **EXCAVATION**

- 2.1 Inspection in-site
- 2.2 Dealing with water
- 2.3 Excavation Dimensions
- 2.4 Rock
- 2.5 Blasting
- 2.6 Bottoms for excavations to receive foundations
- 2.7 Hardcore filling
- 2.8 Materials found in excavations

3. **CONCRETE WORK**

- 3.1 Architect/Engineer
- 3.2 Code of Practice
- 3.3 Supervision
- 3.4 Contractor's Plant, Equipment and Construction Procedures
- 3.5 Level and Foundations
- 3.6 Tolerances
- 3.7 Materials Generally
- 3.8 Samples and Testing
- 3.9 Cement
- 3.10 Aggregates#Water
- 3.11 Admixtures

4. **CONCRETE STRENGTHS**

- Grades of concrete
- Measuring of concrete materials
- Weigh batching machine
- Concrete mixes A,B and C

- Alternative 1: Design mix
- Alternative 2: Volume mix
- Ready Mix Concrete
- Waterproof Concrete
- Changing Proportions to Aggregates
- Testing Equipment
- Work Cube Tests



5. **CONSTRUCTION JOINTS**

- 5.1 Position of construction joints
- 5.2 Maximum distance between construction joints
- 5.3 Preparation of construction joints

6. **EXPANSION AND CONTRACTION JOINTS**

7. **WATERBARS**

- 7.1 Type
- 7.2 Joints
- 7.3 Additional waterbars
- 7.4 Formwork waterbars

8. **EMBEDDED CONCRETE**

9. **MIXING AND PLACING OF CONCRETE**

- 9.1 Concrete mixer
- 9.2 Concrete consistency
- 9.3 Conveying of concrete
- 9.4 Depositing of concrete
- 9.5 Placing of concrete under water
- 9.6 Precautions for mixing, conveying and depositing concrete

10. **COMPACTION OF CONCRETE**

- 10.1 Depth of compaction
- 10.2 Vibration of concrete
- 10.3 Internal vibrators
- 10.4 External vibrators

11. **CURING AND PROTECTION**

- 11.1 Periods and means of curing and protection
- 11.2 Protection of foundation concrete
- 11.3 Excessive loads before curing

12. **FAULTY CONCRETE**

13. **REINFORCEMENT**

- 13.1 Types of Reinforcement
- 13.2 Testing of Reinforcement
- 13.3 Fabric Reinforcement
- 13.4 Fixing of Rod Reinforcement
- 13.5 Spacing Blocks

- 13.6 Concrete cover to Reinforcement
- 13.7 Position and correctness of Reinforcement
- 13.8 Protection of exposed Reinforcement

14. **CHASES HOLES ETC. IN CONCRETE**

15. **POSITION OF ELECTRICAL CONDUITS IN CONCRETE**

16. **FORMWORK**

- 16.1 Materials and Design
- 16.2 Construction
- 16.3 Preparation for Concreting
- 16.4 Defective Formwork
- 16.5 Formwork to construction joints etc.
- 16.6 Stripping of formwork
- 16.7 Making good
- 16.8 Fairface etc.
- 16.9 Related unformed surfaces

17. **PRECAST CONCRETE WORK**

- 17.1 General Requirements
- 17.2 Steam Curing
- 17.3 Method of Handling
- 17.4 Repairs
- 17.5 Moulds

18. **COMPOSITE FLOOR SLABS**

- 18.1 Size, Type and concrete mix for floor blocks
- 18.2 Composite floor construction
- 18.3 Fixing of rib reinforcement

19. **NOTES CONCERNING MEASUREMENT AND PRICING CONCRETE WORK**

